

45630

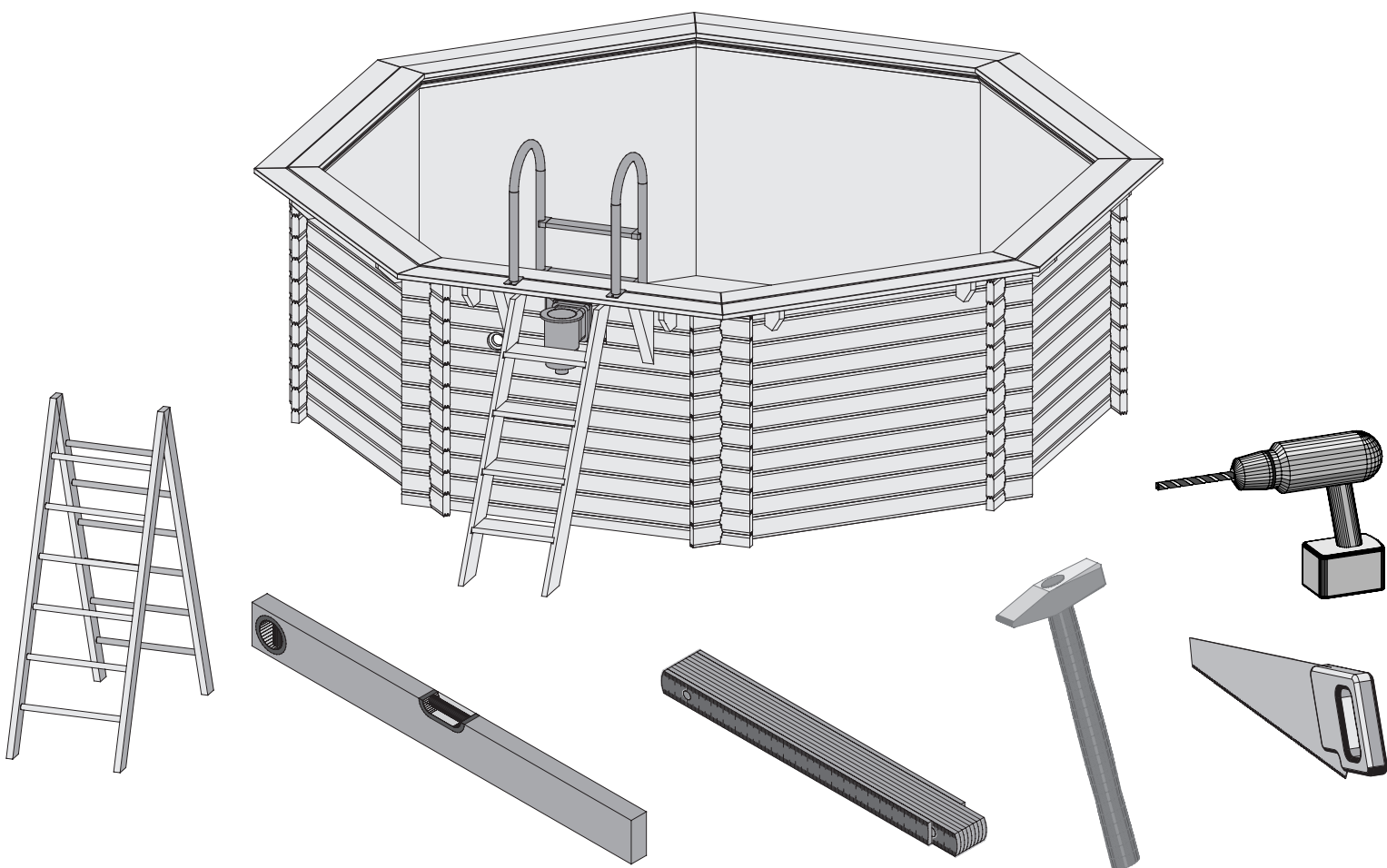

 **Aufbauanleitung**

 **notice de montage**

 **Building Instructions**

 **montagehandleiding**

 **Instrucciones de construcción**

 **Istruzioni per il montaggio**

 **Service-Hotline:+49 421 38693 33**



Vergleichen Sie zuerst die Materialliste mit Ihrem Paketinhalt! Bitte haben Sie Verständnis, dass Beanstandungen nur im nicht aufgebauten Zustand bearbeitet werden können!



Commencez par comparer la liste du matériel avec le contenu de votre paquet! Sachez que nous traitons uniquement les réclamations concernant le matériel à l'état non monté!



First compare the list of materials with your package contents! Please understand that complaints can be processed in the non-built status only!



Vergelijk eerst de lijst van materialen met de inhoud van uw pakket! Reclamaties kunnen alleen in behandeling worden genomen zolang de onderdelen nog niet zijn gemonteerd!



En primer lugar, compare la lista de material con el contenido del paquete. Rogamos entienda que las reclamaciones sólo pueden ser tramitadas antes de montar el objeto!



Confrontate questa distinta materiali prima con il contenuto del pacchetto! Vi preghiamo di comprendere che eventuali reclami possono essere accolti solo prima del montaggio!



45630

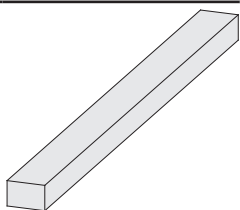

4 x B1	420 x 140 x 26mm	ID 39882
1 x B2	304 x 121 x 38mm	ID 39808

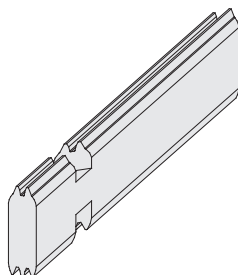

2 x W4	731 x 121 x 38mm	ID 39311
--------	------------------	----------

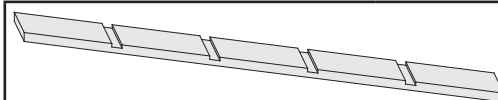

1 x M3	1417 x 140 x 26mm	ID 39880
--------	-------------------	----------

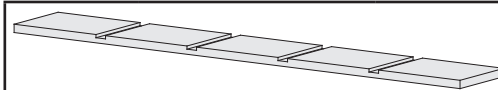

1 x M4	1417 x 140 x 26mm	ID 39881
--------	-------------------	----------

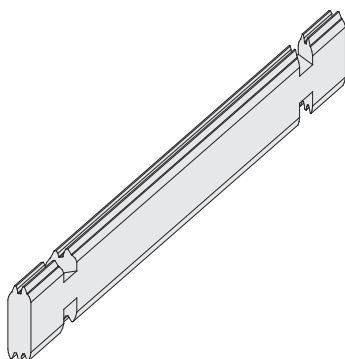

81 x W1	1773 x 121 x 38mm	ID 39276
---------	-------------------	----------

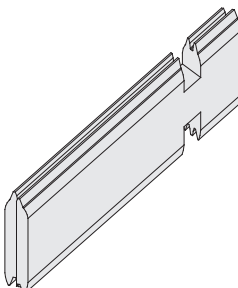

2 x W5	731 x 121 x 38mm	ID 39315
--------	------------------	----------

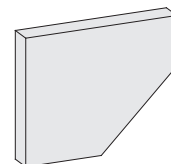

16 x M5	170 x 140 x 26mm	ID 42932
---------	------------------	----------

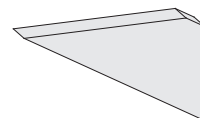

2 x M6	400 x 155 x 55mm	ID 72767
--------	------------------	----------

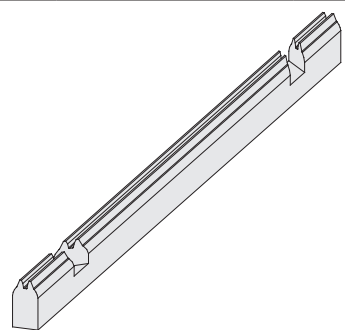

4 x W2	1773 x 71 x 38mm	ID 39365
--------	------------------	----------

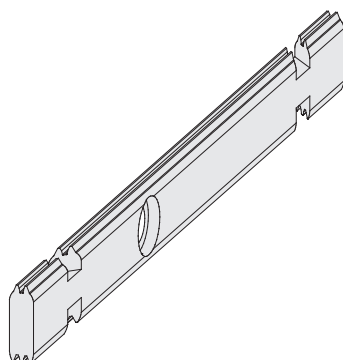

1 x W6	1773 x 121 x 38mm	ID 39342
--------	-------------------	----------

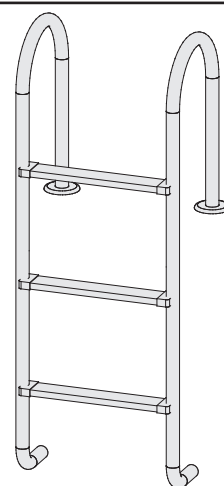

1 x	ID 39258
-----	----------

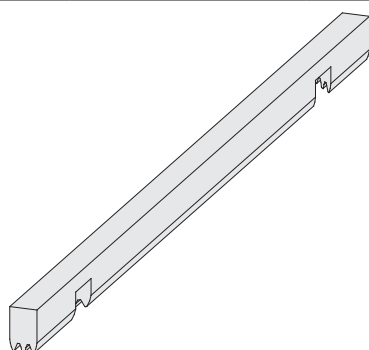

4 x W3	1773 x 60 x 38mm	ID 39286
--------	------------------	----------

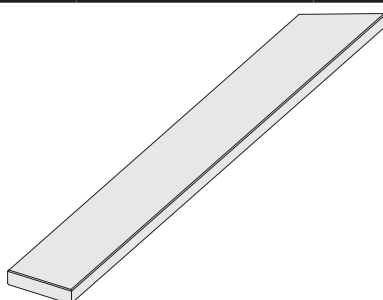

8 x M1	1536 x 140 x 26mm	ID 42933
8 x M2	1656 x 140 x 26mm	ID 42939

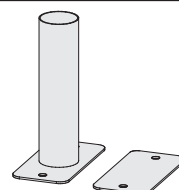

2 x	ID 39259
-----	----------

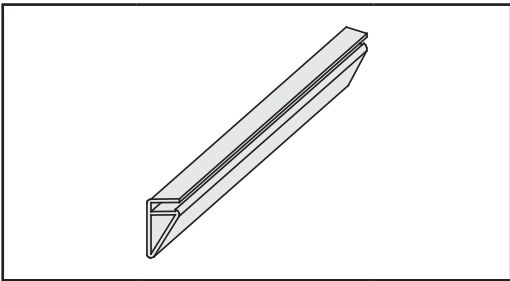

8 x D1 | 1800 x 33 x 17mm | ID 39263

2

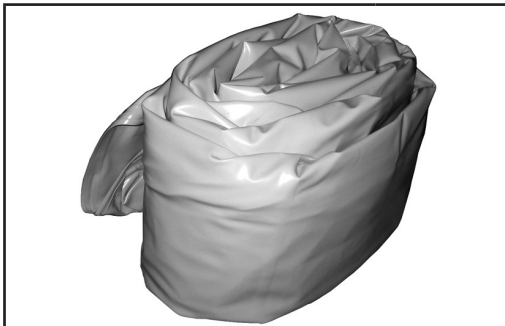

1 x | ID 39253

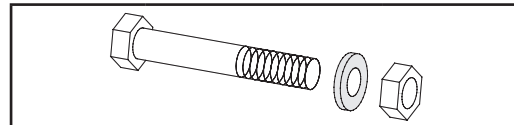

4 x | 10 x 50mm | ID 39439

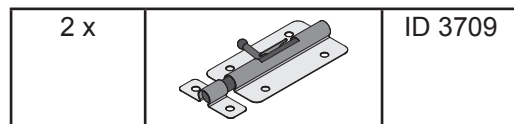

2 x | ID 3709

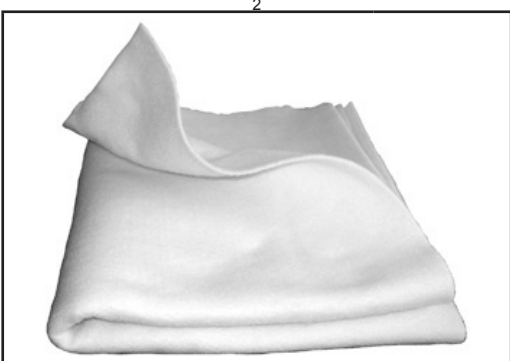

14m² | ID 39260

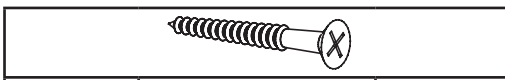

90 x | 4 x 35mm | ID 39398

120 x | 4 x 50mm | ID 39399

40 x | 6 x 80mm | ID 39397

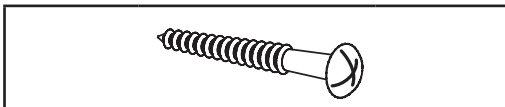

70 x | 4 x 25mm | ID 39437

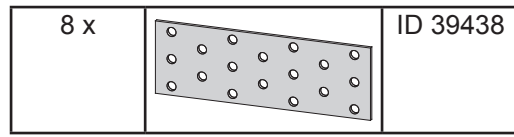

8 x | ID 39438

01

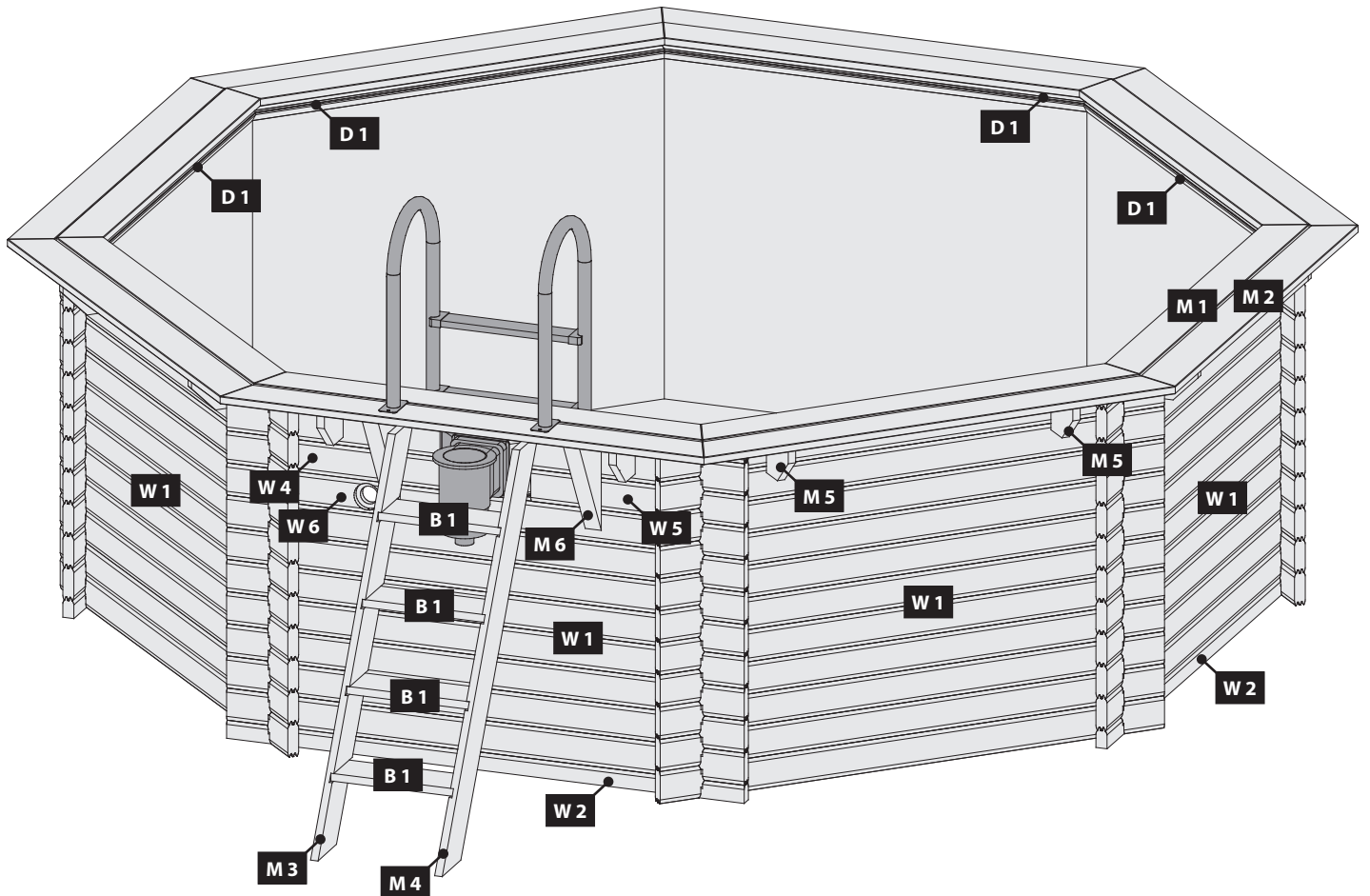

02

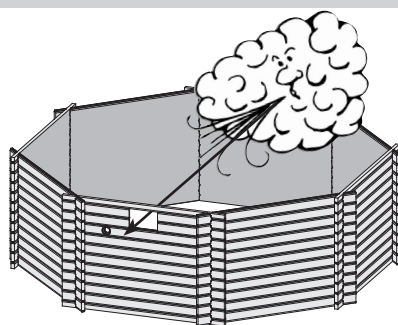

!!! A=B=C=D !!!

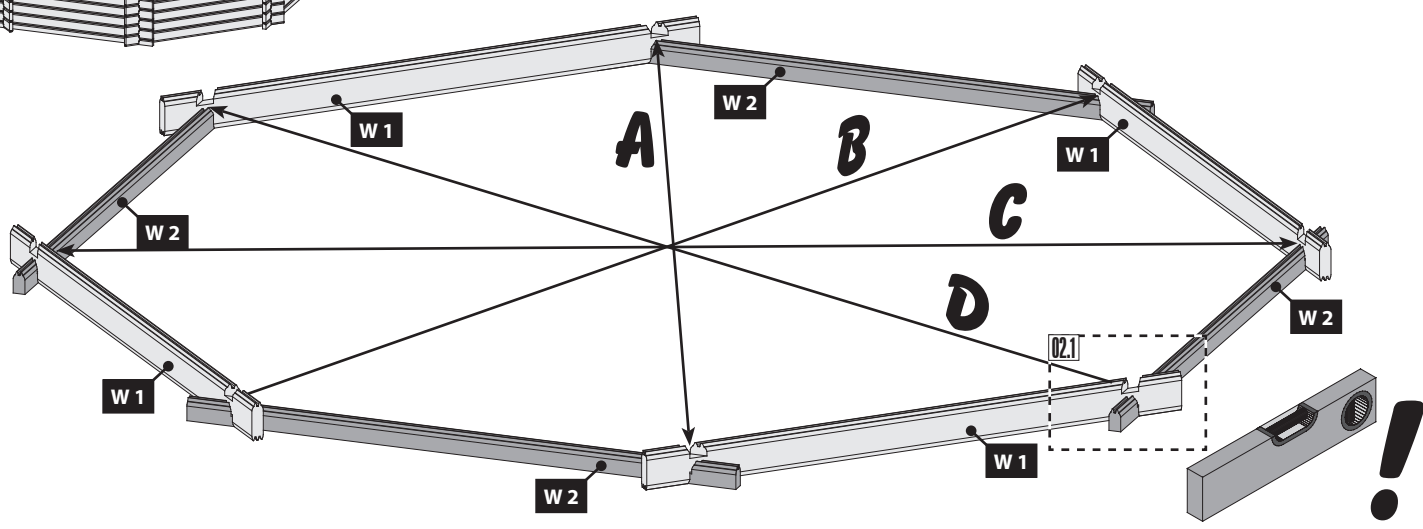

02.1-1

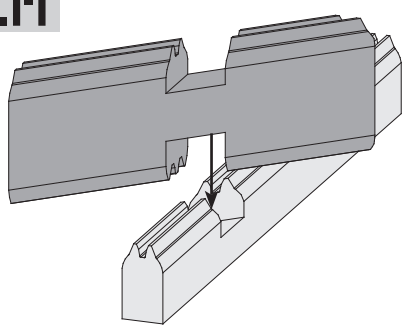

02.1-2

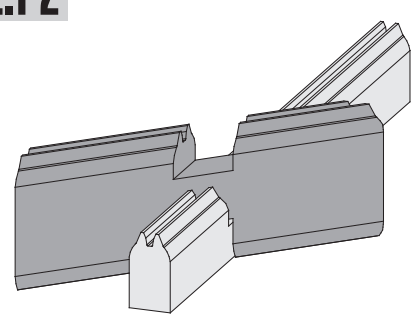

02.1-3

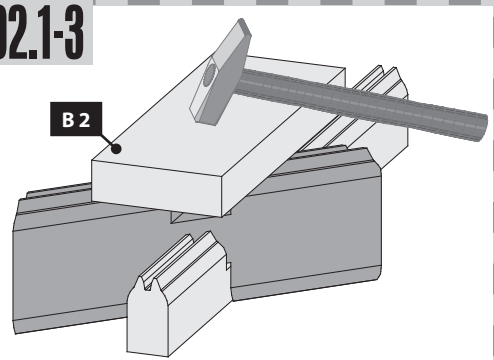

03

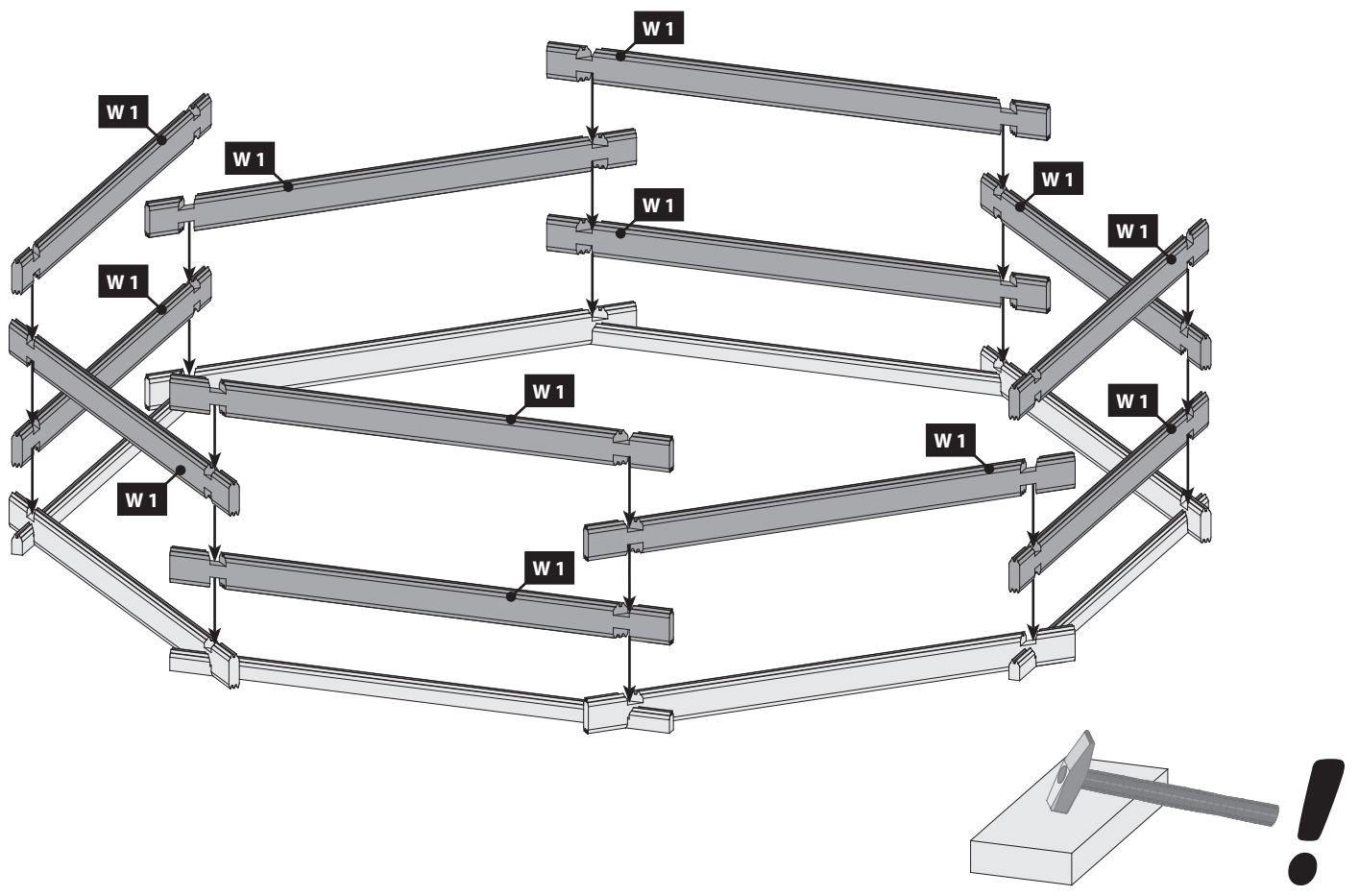

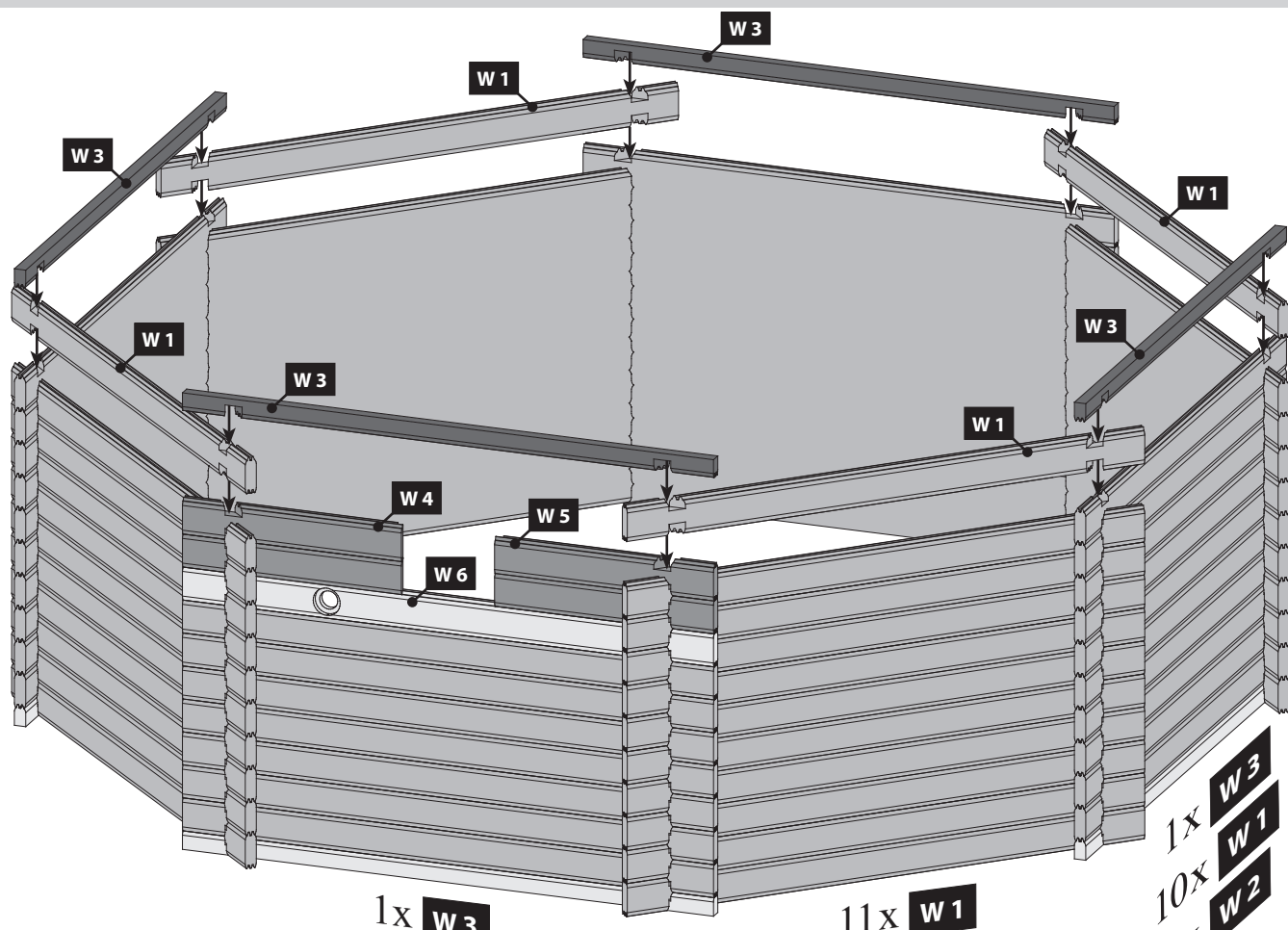

- 1x W3
- 2x W4
- 1x W6
- 7x W3
- 1x W2
- 2x W5
- 2x W5
- 11x W1

- 1x W3
- 10x W1
- 1x W2

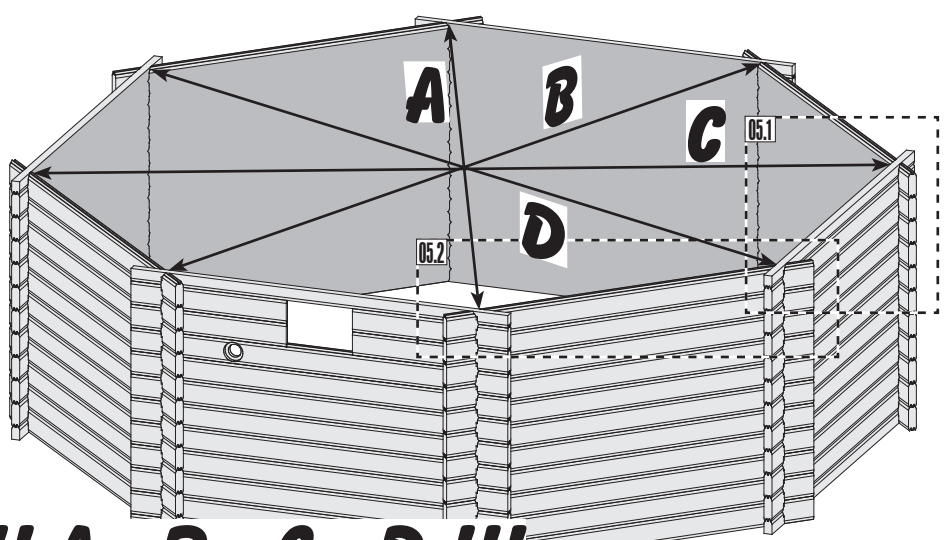
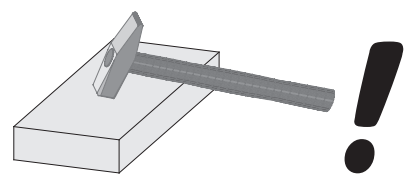

!!! A=B=C=D !!!

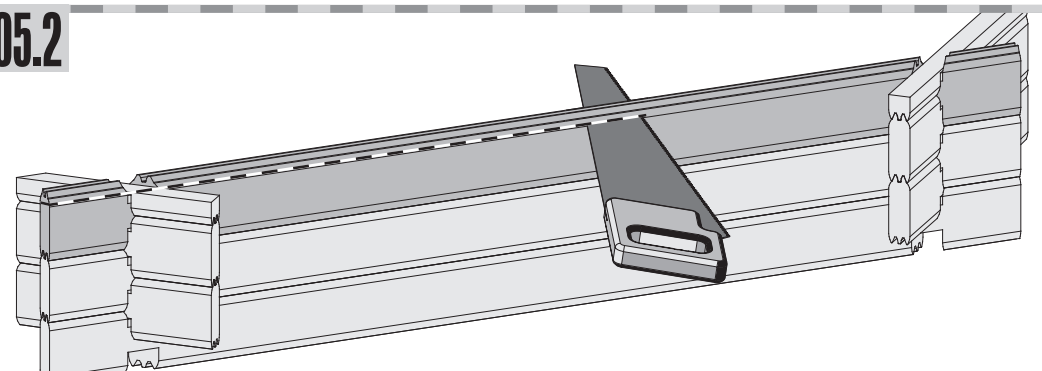
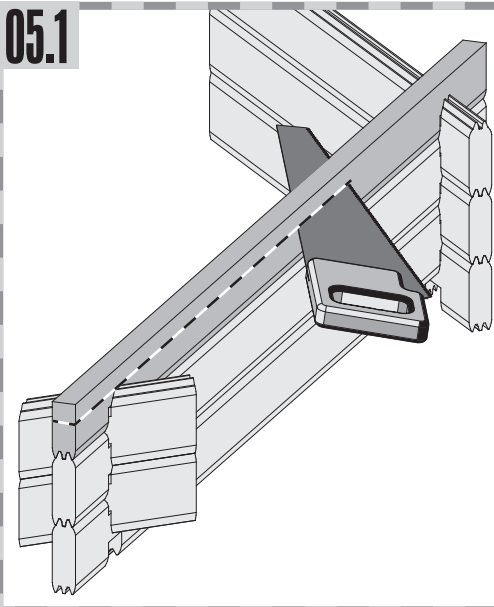

06

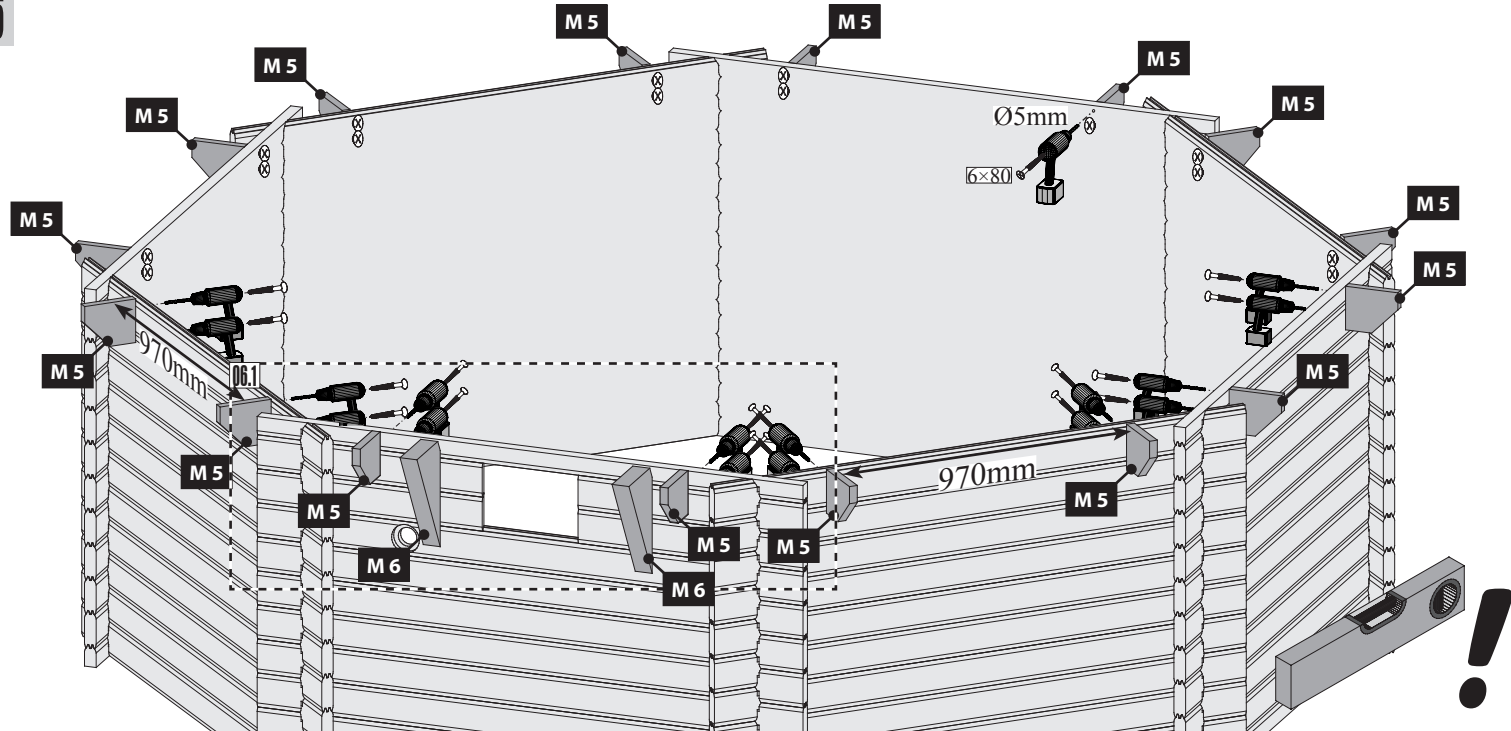

06.1

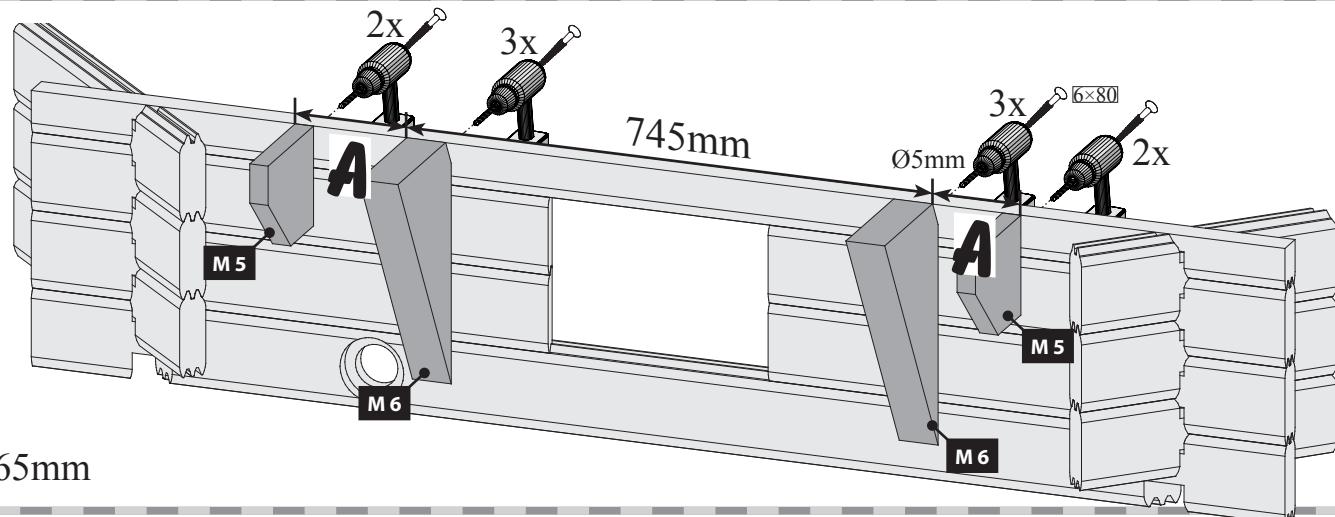

07

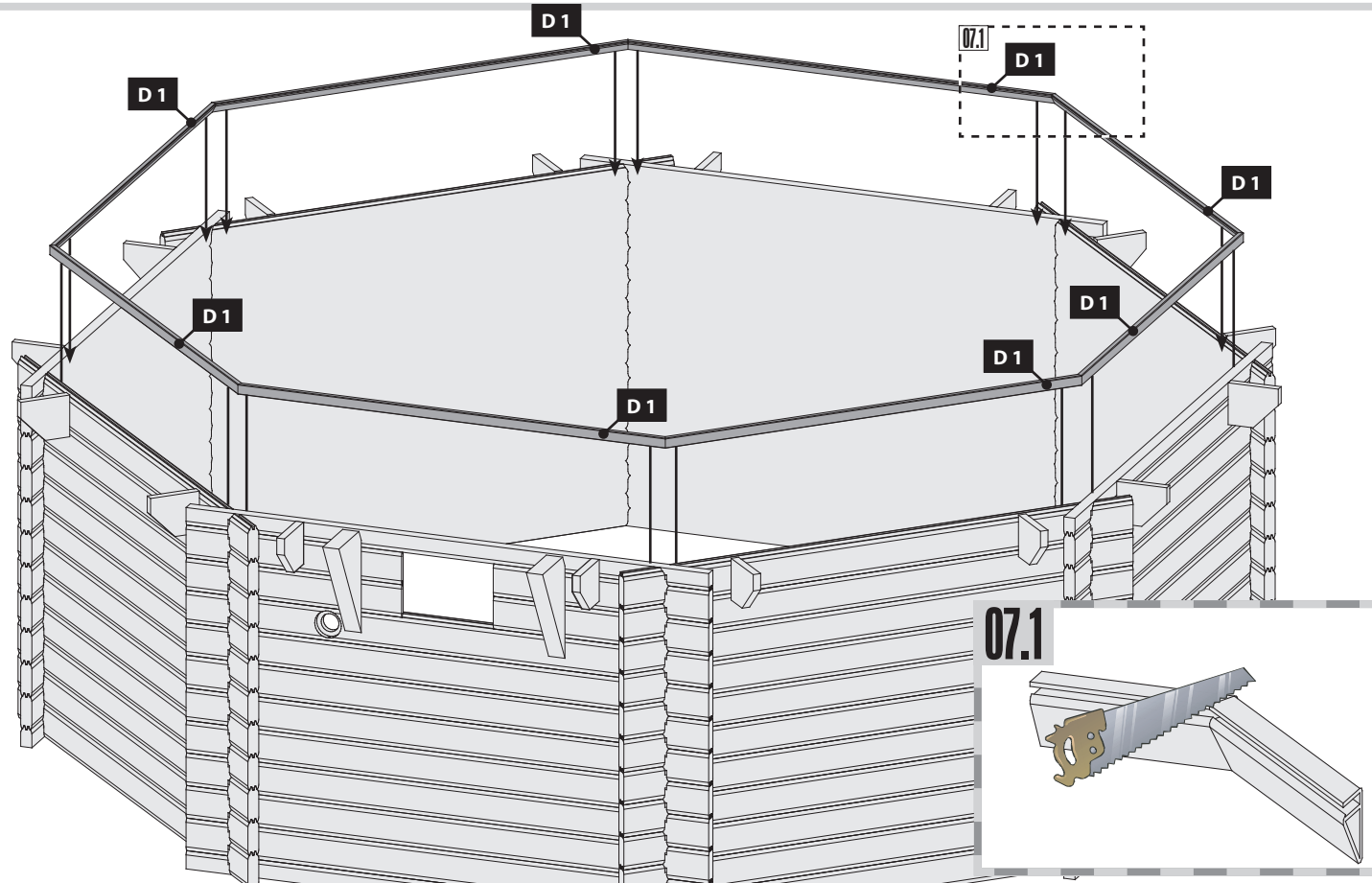

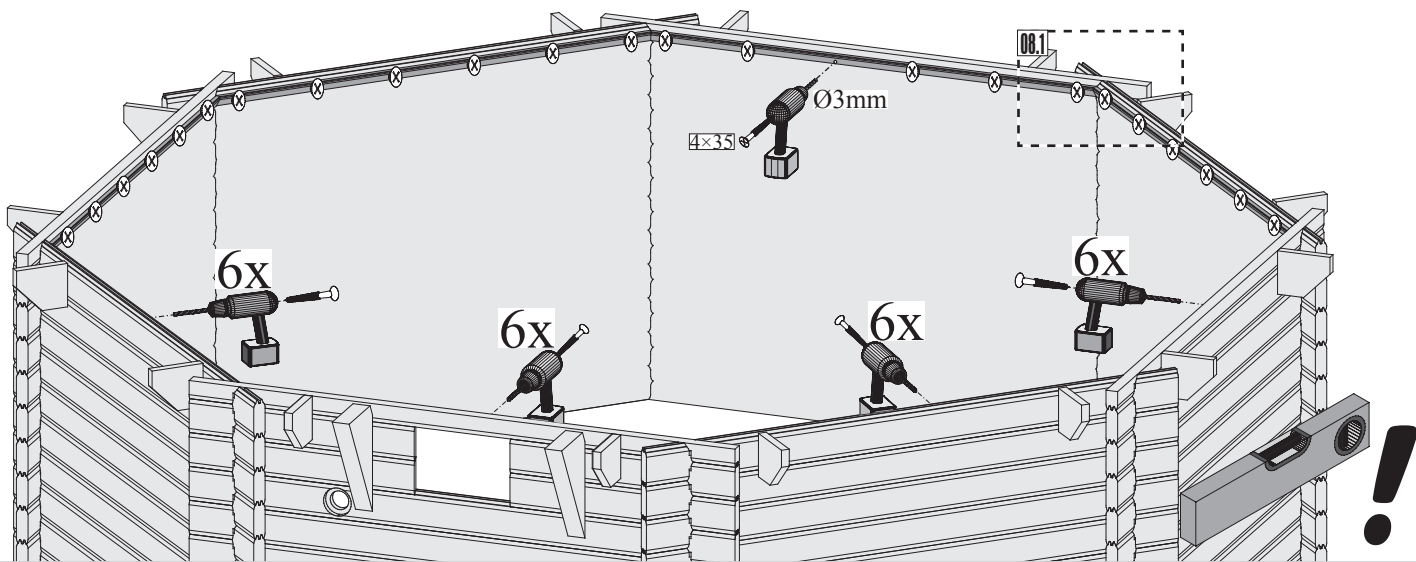

08.1

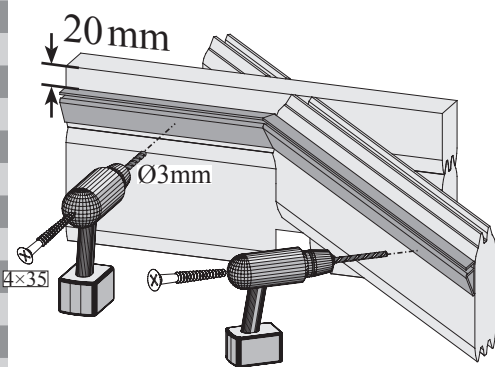

09

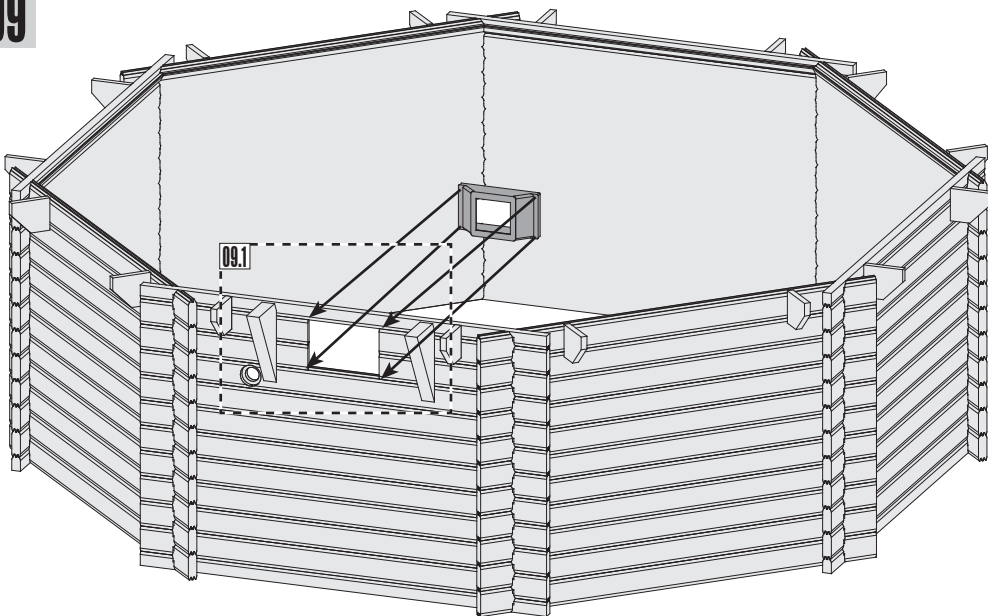

09.1-1

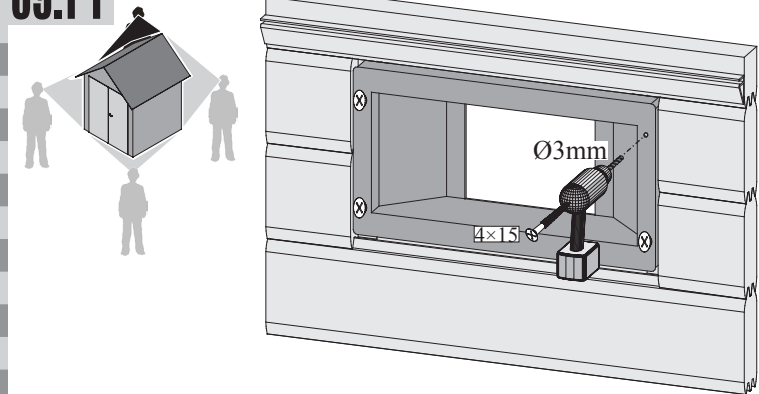

09.1-2

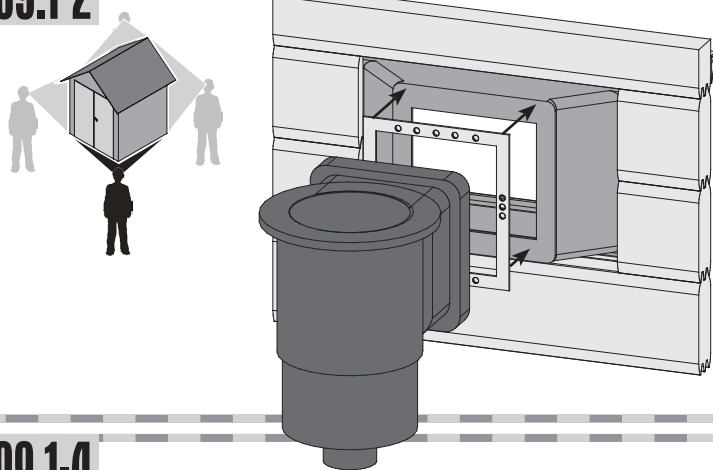

09.1-3

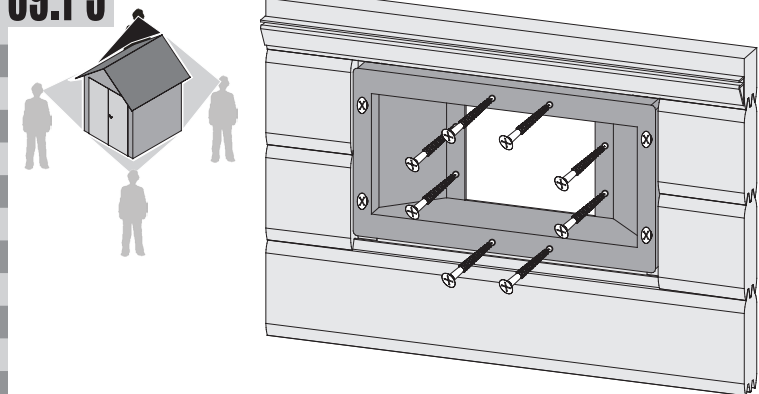

09.1-4

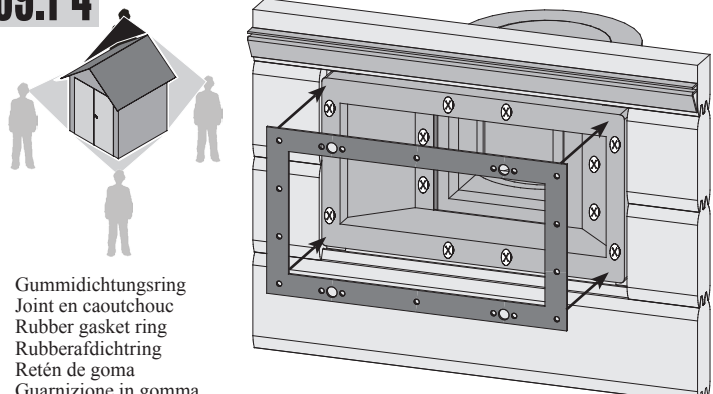

Gummidichtungsring
 Joint en caoutchouc
 Rubber gasket ring
 Rubberafdichting
 Retén de goma
 Guarnizione in gomma

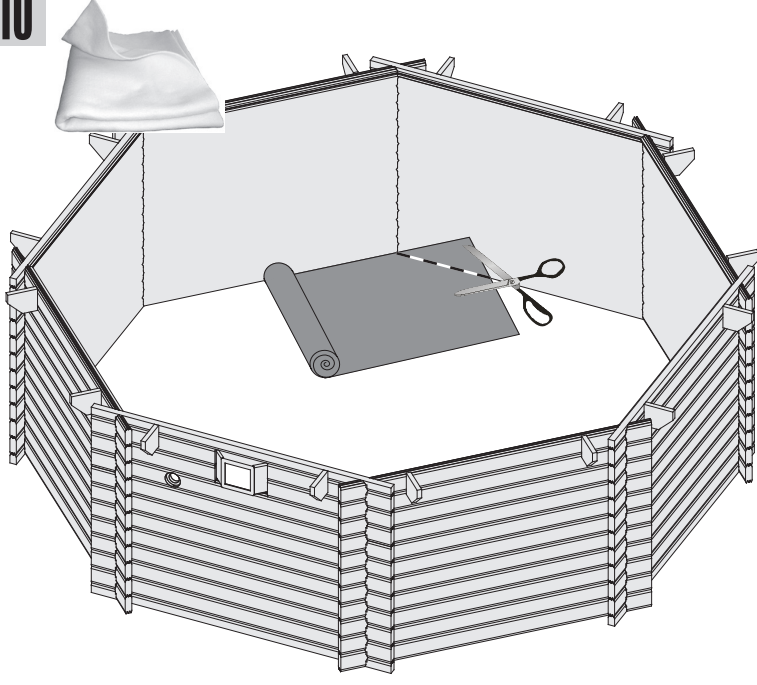
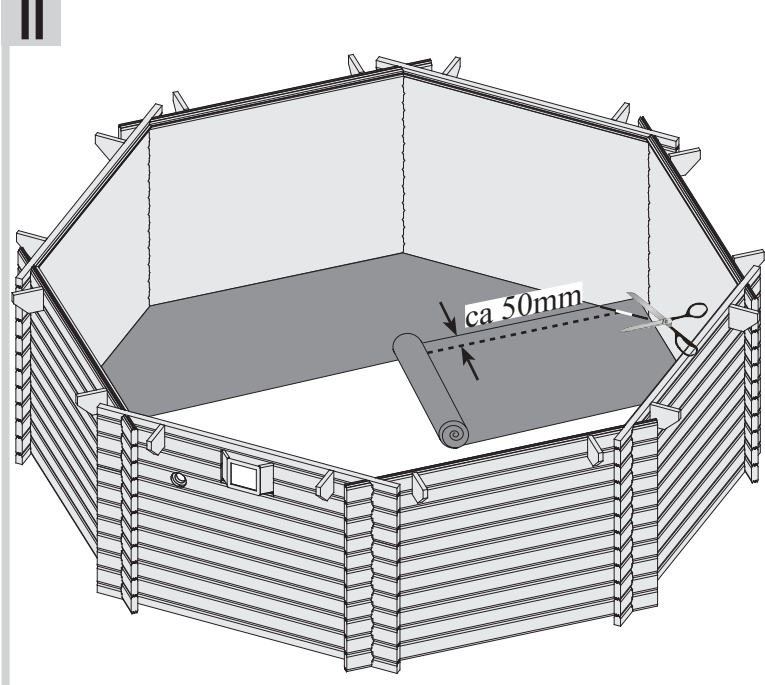
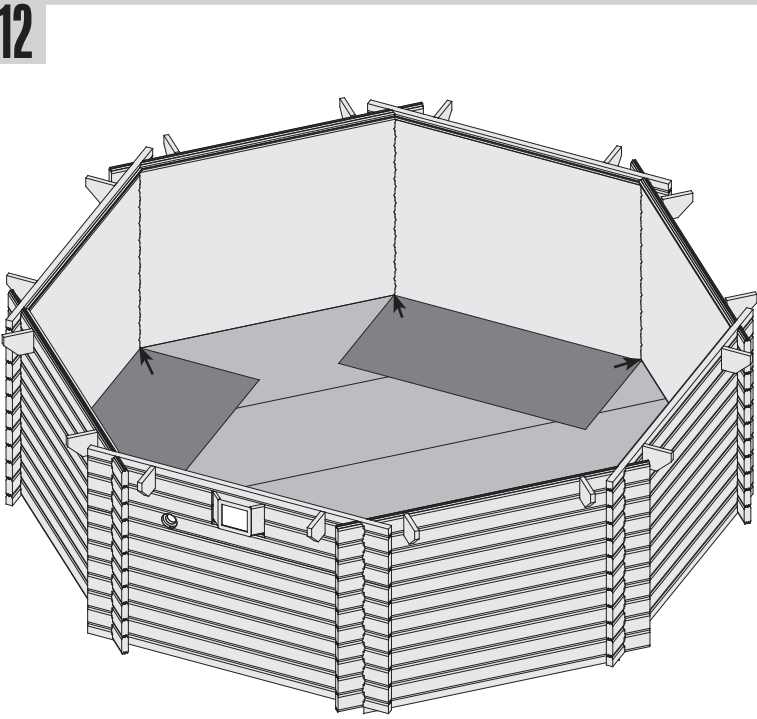
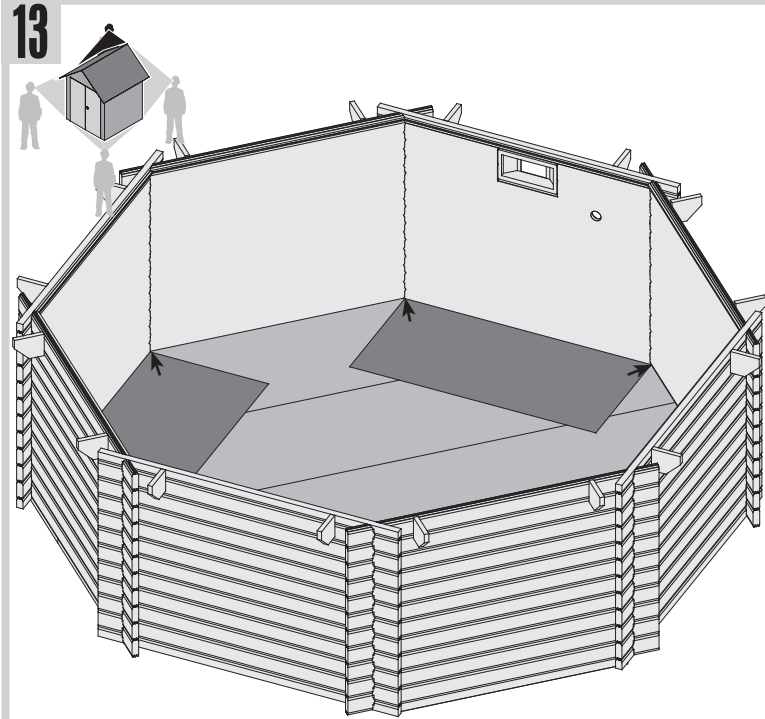
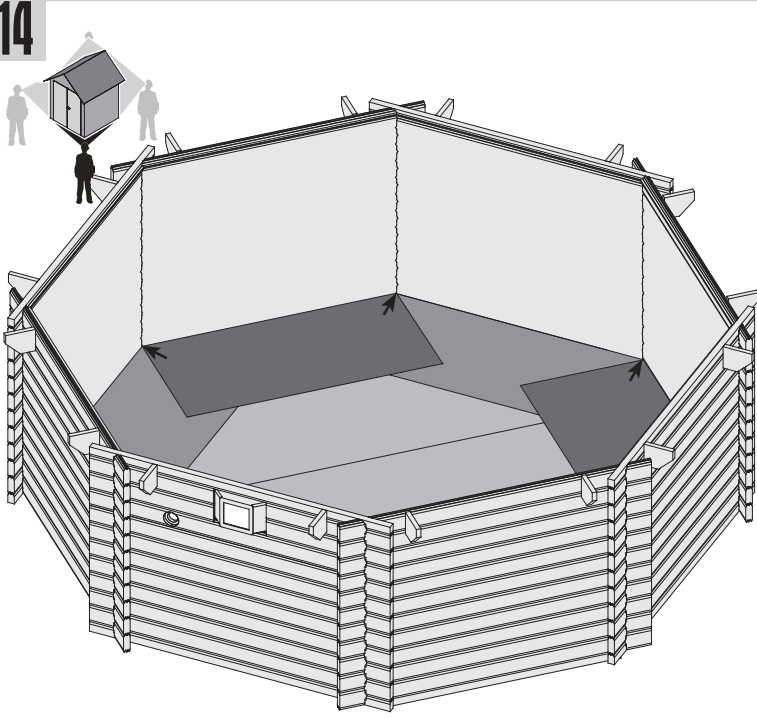
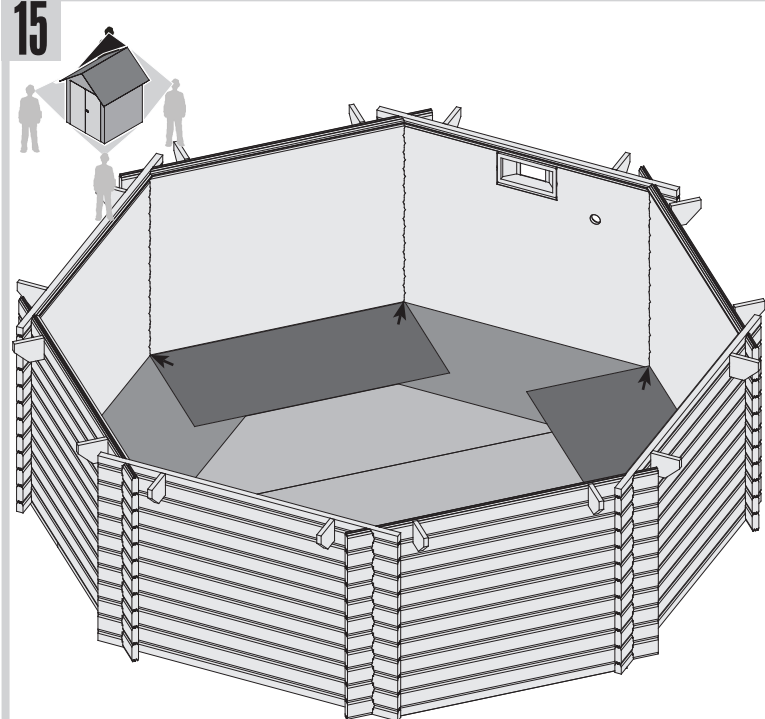
10**11****12****13****14****15**

16

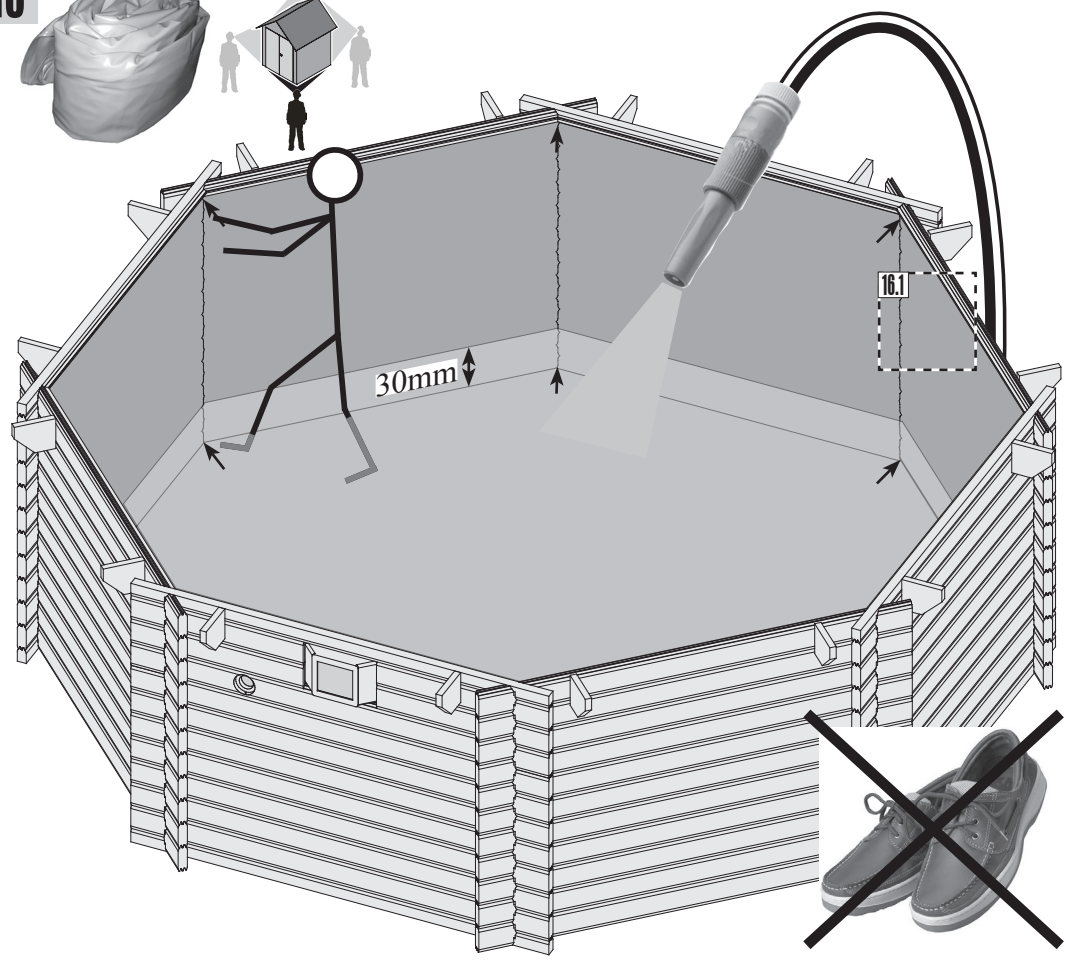
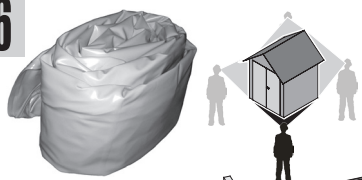

30mm

16.1



16.1-1

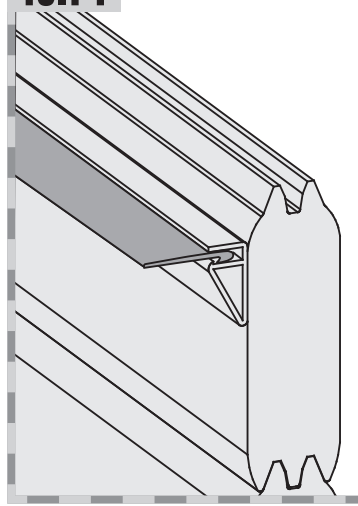

16.1-2

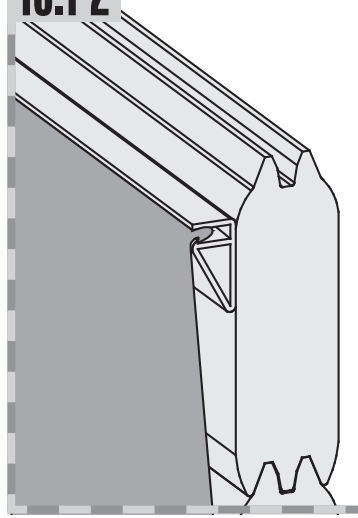

17

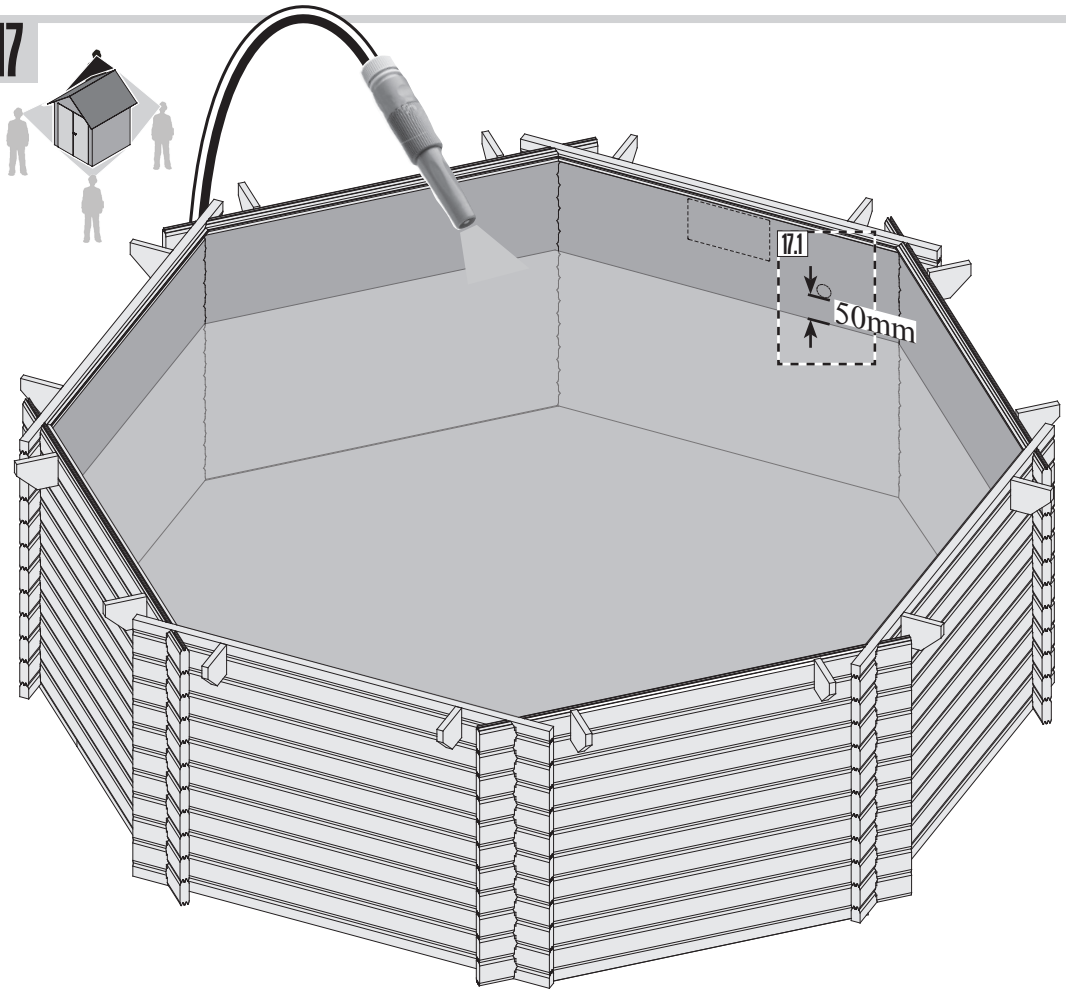
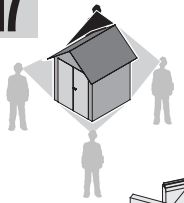

50mm

17.1

17.1-2

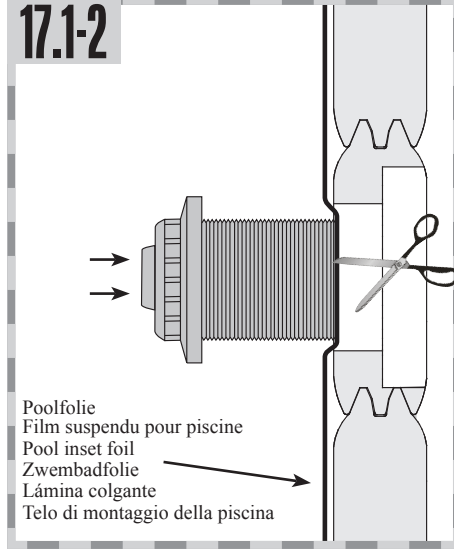

Poolfolie
Film suspendu pour piscine
Pool inset foil
Zwembadfolie
Lámina colgante
Telo di montaggio della piscina

17.1-2

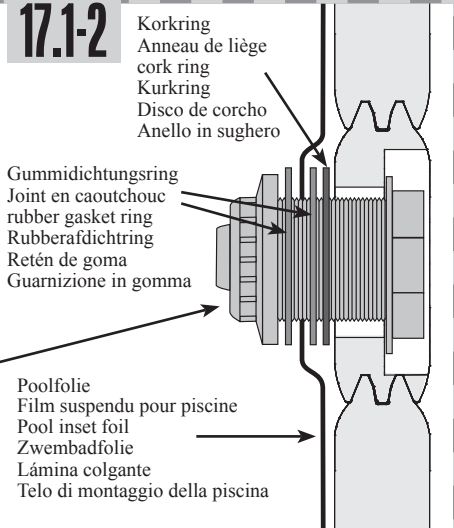

Korkring
Anneau de liège
cork ring
Kurkring
Disco de corcho
Anello in sughero
Gummidichtungsring
Joint en caoutchouc
rubber gasket ring
Rubberafdichtring
Retén de goma
Guarnizione in gomma

Einlaufdüse
Tuyère d'alimentation
inlet nozzle
Zwembadfolie
Tobera de entrada
Bocchettone di afflusso

Poolfolie
Film suspendu pour piscine
Pool inset foil
Zwembadfolie
Lámina colgante
Telo di montaggio della piscina

 **Zuschnitt der Düse**

 **Recorte para tobera**

 **Cutting the liner and fitting the backflow inlet nozzle**

 **Découpe buse**

 **Toglio per condotto**

 **Uitsnijden van instroomopening**

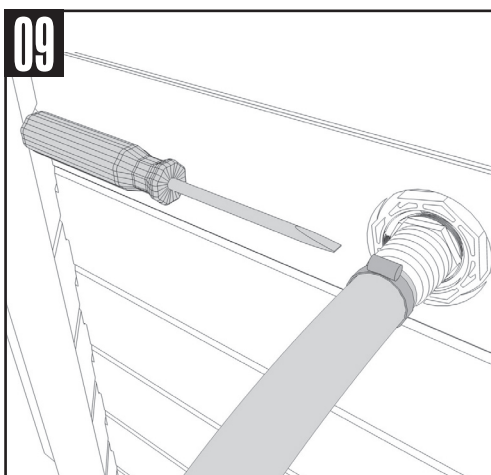
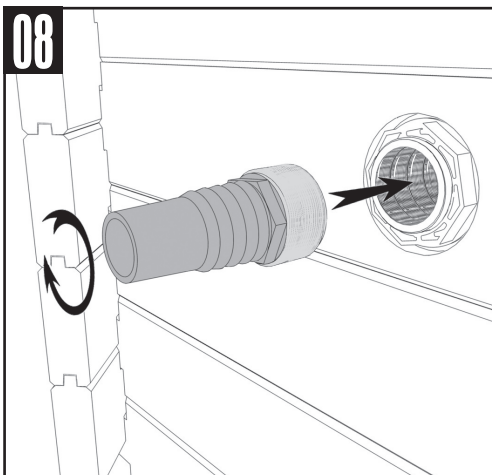
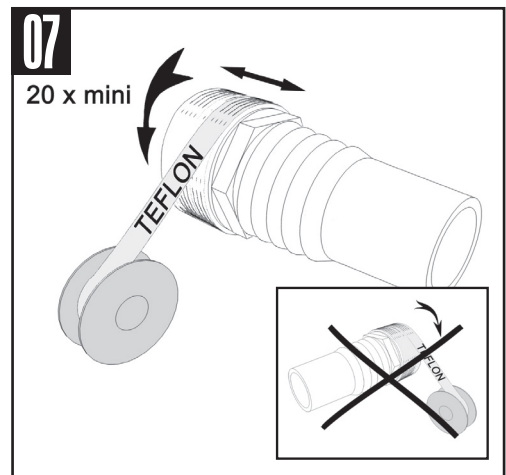
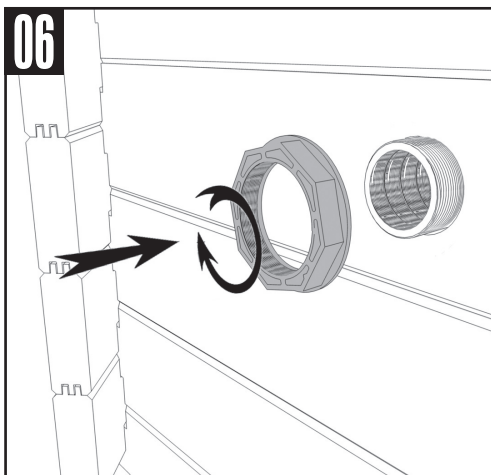
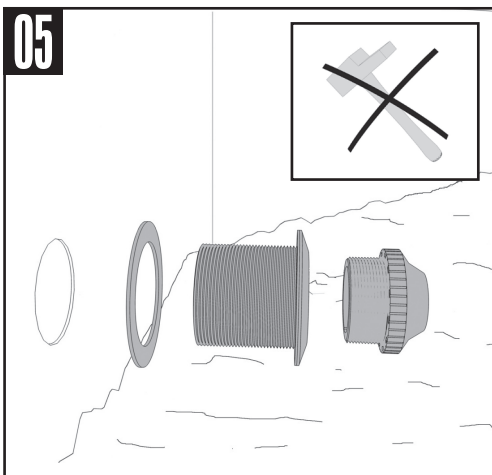
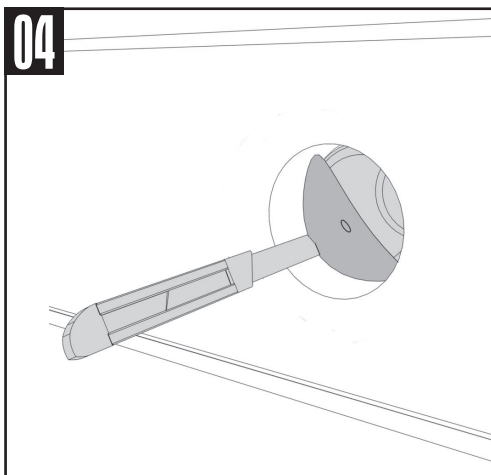
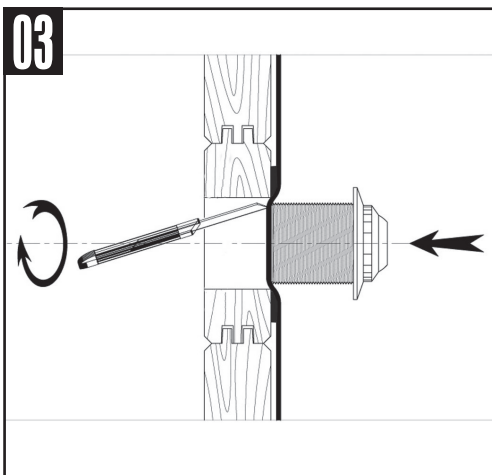
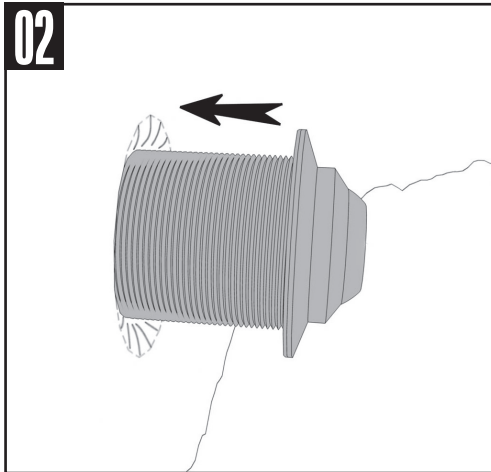
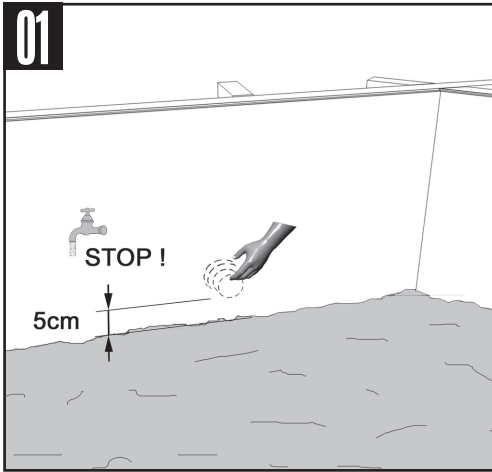

18

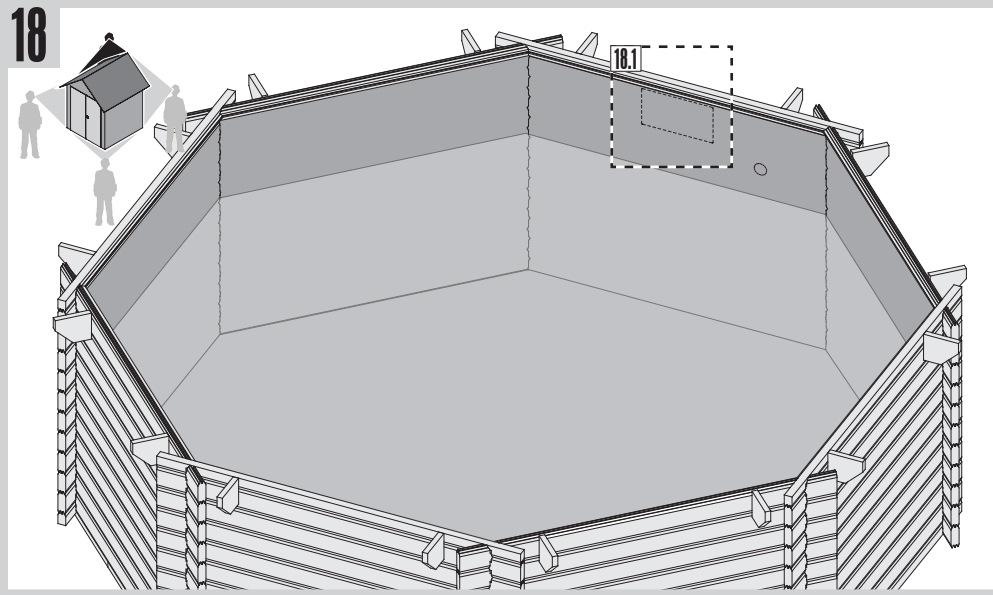

18.1-1

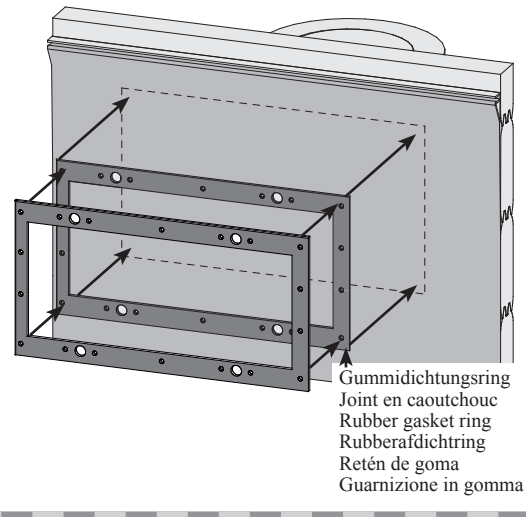

Gummidichtungsring
 Joint en caoutchouc
 Rubber gasket ring
 Rubberafdichting
 Retén de goma
 Guarnizione in gomma

18.1-2

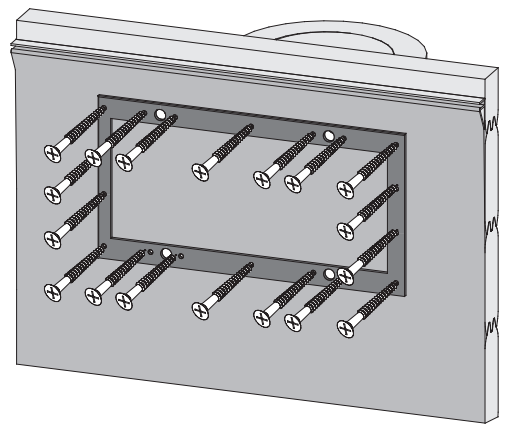

18.1-3

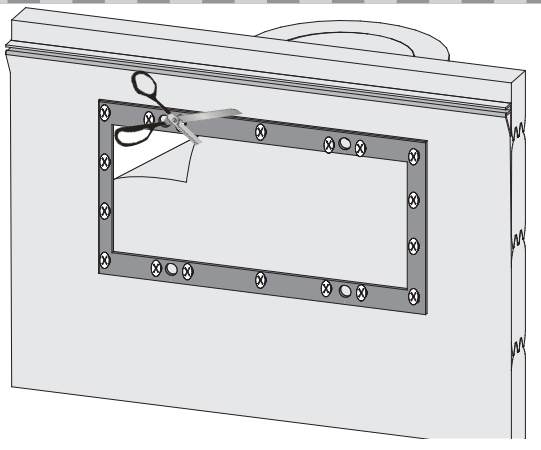

19

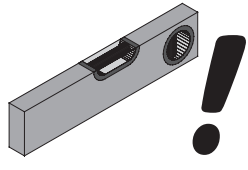
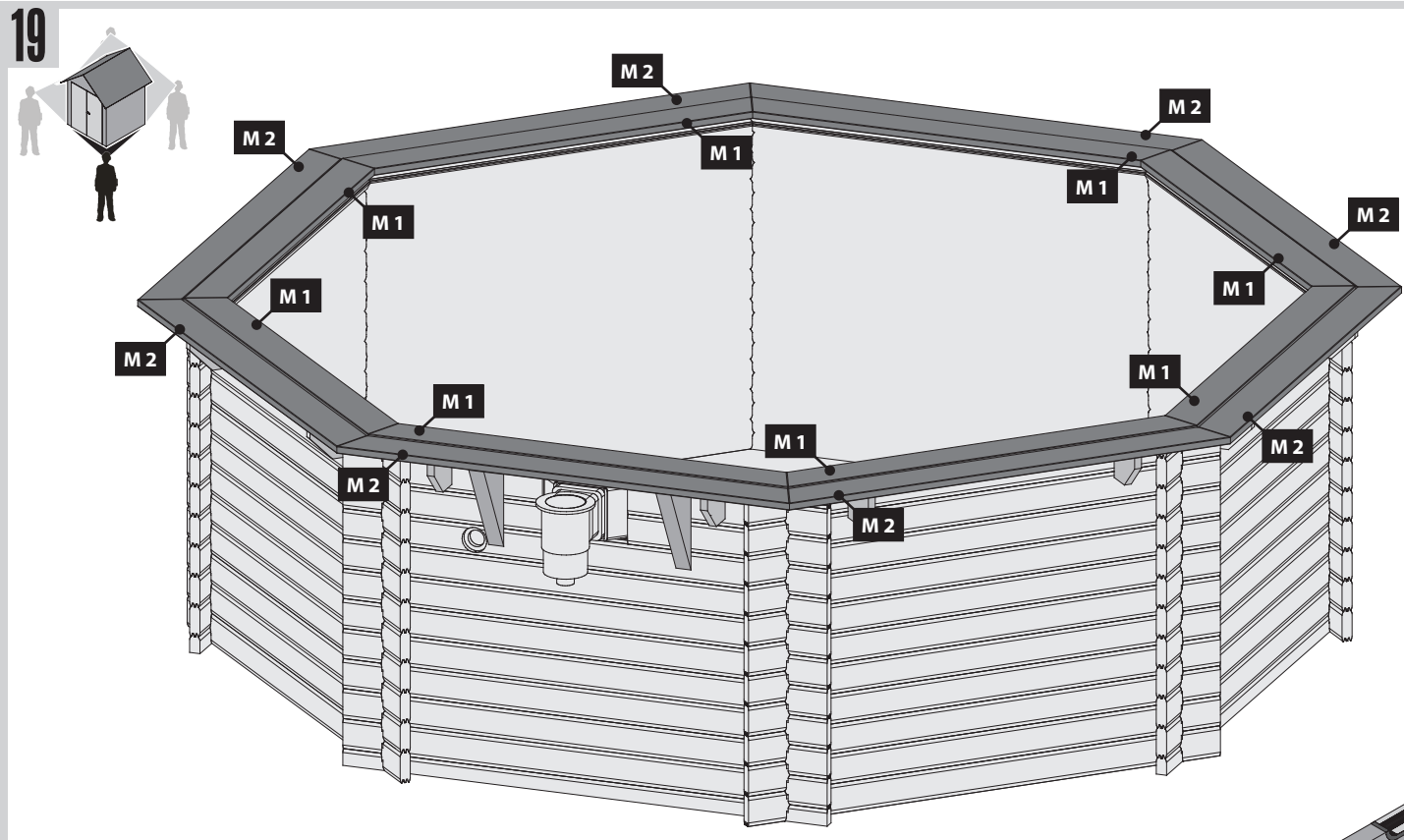

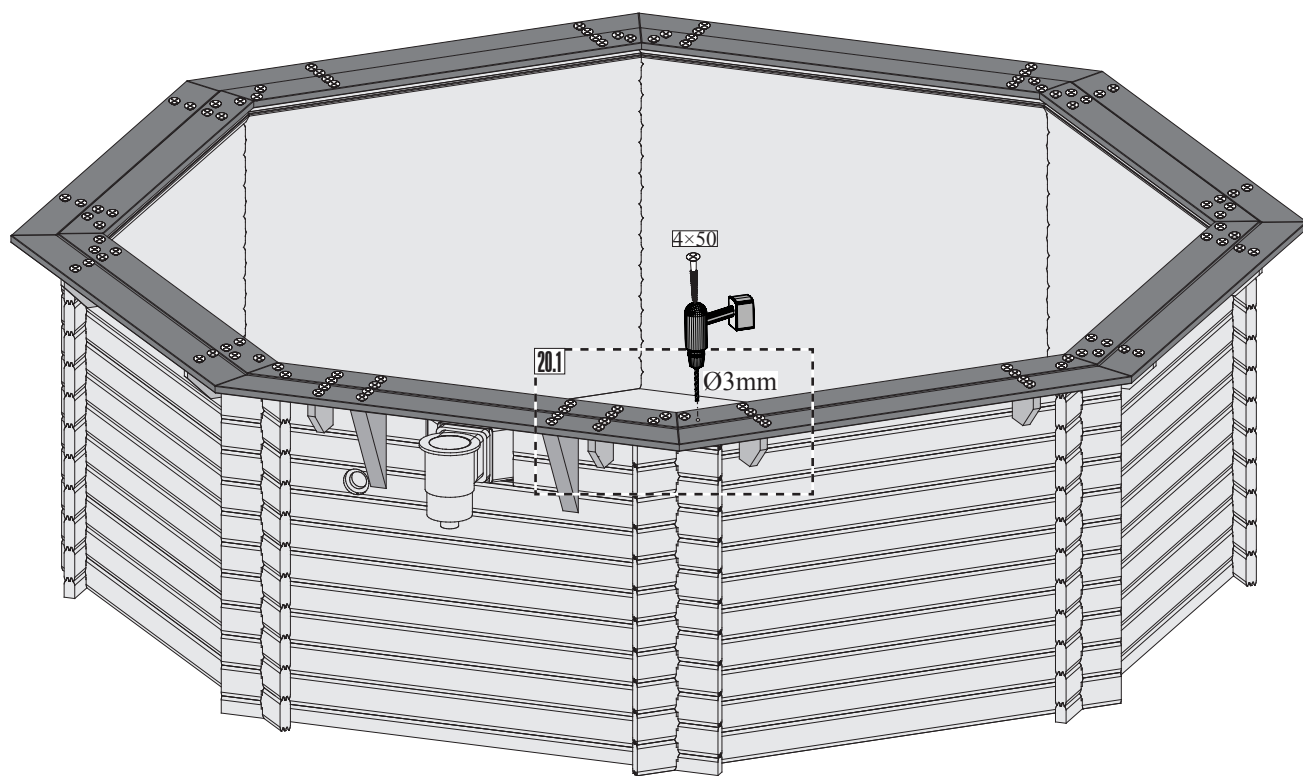

20.1-1

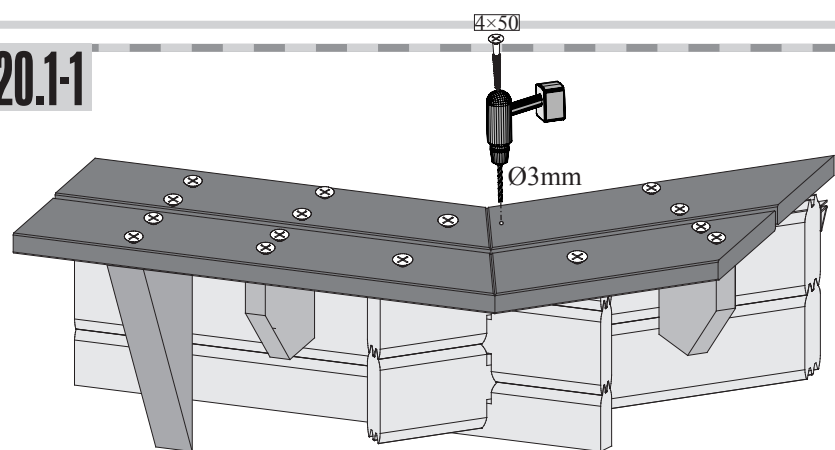

20.1-2

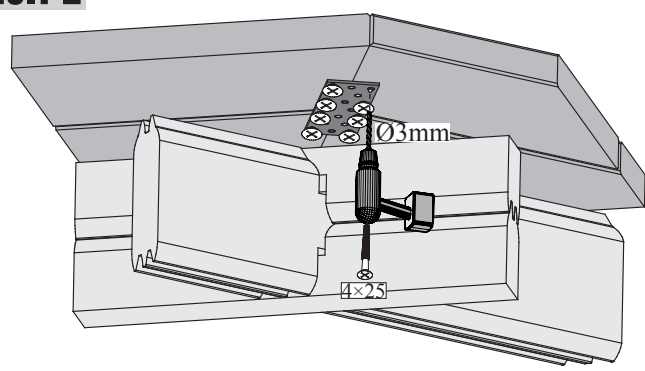

21

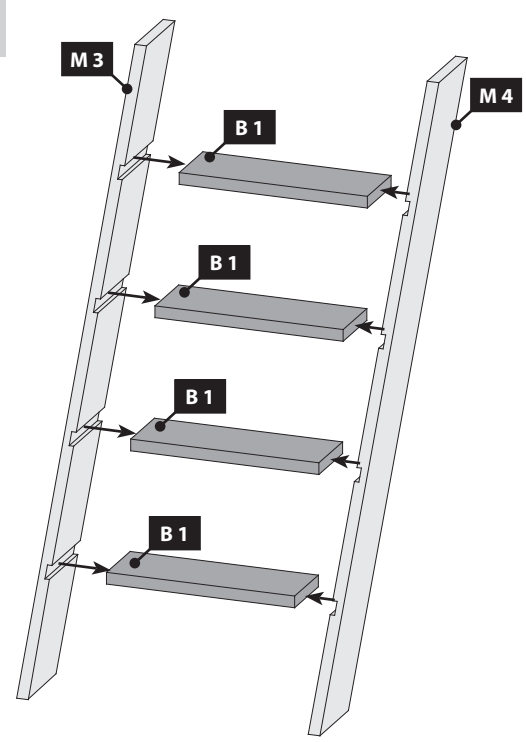

22

