

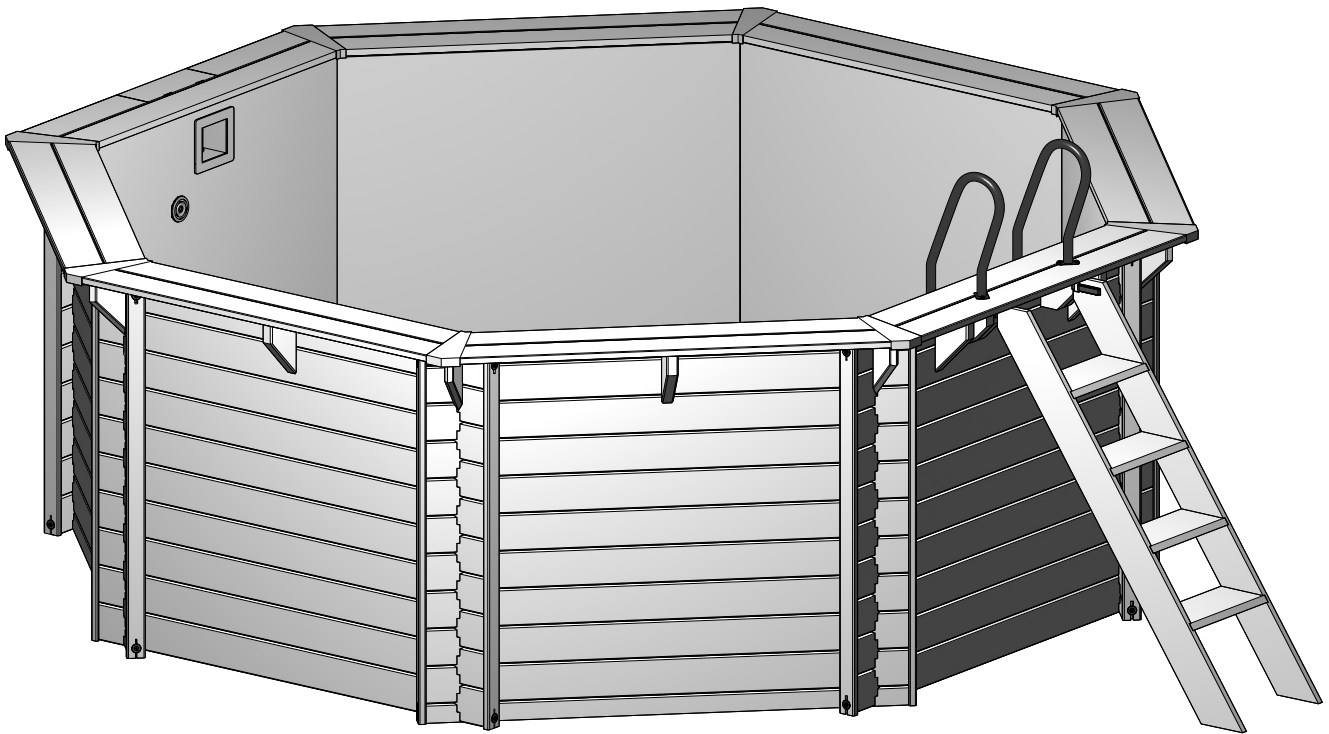

Paradies Pool

HOLZPOOL KALEA
Ø [4,36 - 1,38 m]



Anschrift
Lokalisierung
Telefon
E-mail
Website

Paradies Pool GmbH
Bremer Str. 7b, 01665 Klipphausen
035204-786870
kundenservice@paradies-pool.de
www.paradies-pool.de

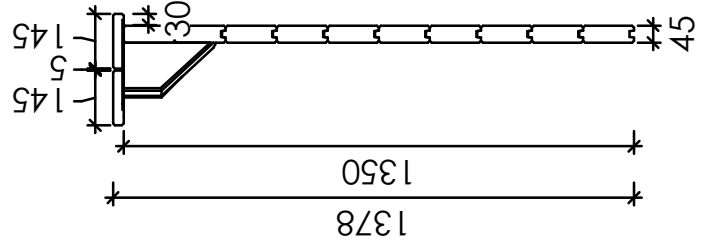
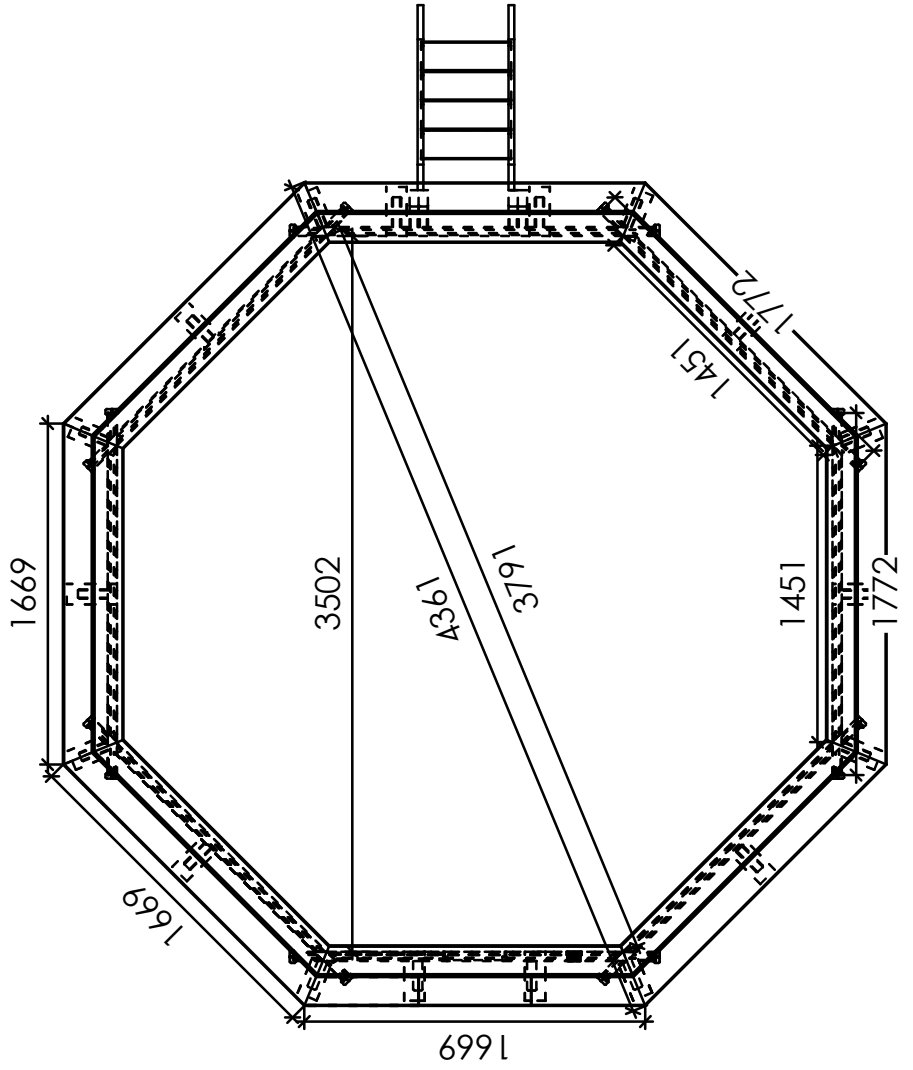
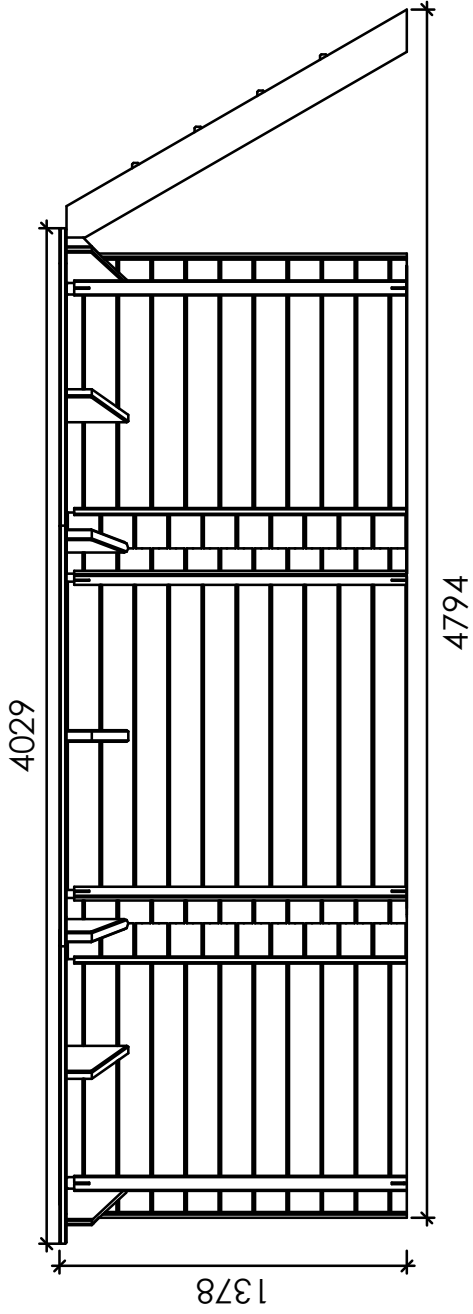

Sie haben mit dem Kauf eines Paradies Pool Schwimmbeckens ein qualitativ hochwertiges Produkt erworben, das sich auf Grund der durchdachten Lösung schnell und einfach aufbauen lässt.

1. Vor dem Aufbau



Bitte lesen Sie diese Anleitung, bevor Sie mit der Beckenmontage beginnen, sorgfältig durch und beachten Sie alle Hinweise. Bitte heben Sie diese Anleitung während der gesamten Nutzungszeit Ihres Schwimmbeckens unbedingt auf. Nur der fachgerechte Aufbau (bzw. Einbau) sichert die Gewährleistungsansprüche. Technische Änderungen und Irrtum behalten wir uns vor.

2. Allgemeine Sicherheitshinweise



Ein Schwimmbecken soll Spaß und Freude bringen, kann aber auch bestimmte Risiken in sich bergen, insbesondere für kleine Kinder oder für Personen, die nicht schwimmen können. Um Unfälle zu vermeiden, sollten Sie die folgenden, Sicherheitshinweise beachten. Als Eigentümer ist Ihre wichtigste Aufgabe, die Badenden an die „Schwimmbecken“-Sicherheitsregeln zu erinnern. Unsere Schwimmbecken sind zur Familiennutzung und im Freien ausgelegt.

- ⊗ Ein Schwimmbecken ist kein Spielzeug. Sein Gebrauch verlangt Voraussicht, Überwachung und Pflege.
- ⊗ Lassen Sie niemals Kinder, die nicht schwimmen können, ohne Aufsicht eines Erwachsenen. Lassen Sie niemals ein Kind allein baden.
- ⊗ Alkoholische Getränke: Benutzen Sie niemals Ihr Schwimmbecken, wenn Sie alkoholische Getränke, Medikamente oder Drogen zu sich genommen haben. Ein Schockzustand, Ohnmacht oder ein schwerer Unfall oder Ertrinken können daraus resultieren.
- ⊗ Springen Sie niemals in Ihr Becken, die Tiefe reicht dafür nicht aus. Springen Sie niemals unvorbereitet ins Wasser, besonders nicht nach einer Mahlzeit (2 Stunden später ist angeraten). Nach einem Sonnenbad oder einer starken Anstrengung riskieren Sie einen Kälteschock.
- ⊗ Entfernen Sie Ihre Leiter/Treppe oder versperren Sie den Zugang zum Schwimmbecken, wenn es nicht in Betrieb ist.
- ⊗ Lassen Sie niemals ein Tier (Hund, Katze, Fisch, usw.) im Schwimmbecken baden. Diese könnten die Folie (Liner) beschädigen, ertrinken oder ersticken.
- ⊗ Schwimmen Sie niemals nach Sonnenuntergang, wenn Sie den Grund des Beckens nicht mehr sehen können. Es liegt in Ihrer Verantwortung, eine ausreichende Beleuchtung Ihres Pools vorzusehen. Ziehen Sie dazu einen Elektriker zu Rate und stellen Sie sicher, dass Ihre Anlage den geltenden elektrischen Regelungen entspricht.
- ⊗ Niemals zwischen der Beckenwand und der Leiter schwimmen (Gefahr eingeklemmt zu werden.)
- ⊗ Vermeiden Sie es, Gegenstände um das Becken zu installieren, die das Erklettern des Beckens erleichtern könnten (Sprungbrett, etc.). Lassen Sie mindestens 2 m Freiraum um das Schwimmbecken herum.
- ⊗ Üben Sie keinen übermäßigen Druck auf die Schwimmbeckenteile aus, wie zum Beispiel Tritte in die Hülle, Besteigen und Setzen auf den Beckenrand, über den Beckenrand klettern, um in das oder aus dem Becken zu steigen. Werfen Sie keine schweren Gegenstände in das Becken, und erzeugen Sie keine großen Wellen.

2.1 Sicherheitshinweise für den Aufbau des Schwimmbeckens



- Zum Aufbau eines Schwimmbeckens sind mindestens 2 Personen erforderlich.



- **Bei der Verwendung von elektrischen Geräten (z. B. Filteranlage, Unterwasserscheinwerfer, Gegenstromanlage usw.) ist zu beachten das sämtliche Elektroarbeiten von einem anerkannten Fachbetrieb gemäß den einschlägigen DIN und VDE-Vorschriften (DIN VDE 0100 Teil 702) durchgeführt werden müssen.**



- ⊗ Berühren Sie nie ein elektrisches Gerät oder versuchen Sie gar dieses zu reparieren. Dies schließt auch Ihr Filtersystem und alle Elektrischen Bauteile mit ein, schon gar nicht, wenn Ihr Körper oder der Erdboden nass sind.



- ⊗ Ihr Schwimmbecken sollte vorsichtshalber nicht direkt unter oberirdischen Stromleitungen installiert werden. Bevor Sie mit dem Erdaushub beginnen, ist es angeraten, die Lage der unterirdischen Kabel und Leitungen bei den Telefon-, Strom und Gas- Unternehmen zu überprüfen. Bitte vergewissern Sie sich, dass keine unterirdischen Leitungen (Gas, Strom, Telefon, Wasser usw.) unter dem Standort, den Sie für Ihren Pool gewählt haben, verläuft.
- ⊗ Da Ihr Schwimmbecken mehrere Tausend Liter Wasser enthält, kann ein schlecht vorbereiteter Untergrund oder ein falsch montiertes Becken schwerwiegende Schäden verursachen. 1 m³ Wasser = 1000 Liter = 1 Tonne!

LEGENDE FÜR ZUSÄTZLICH BENÖTIGTE MATERIALIEN

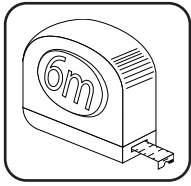

Maßband



Sicherheits-
handschuhe

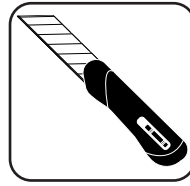

Cuttermesser

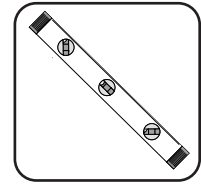

Wasserwaage



Gummi-
hammer



Säge mit
feinem Blatt

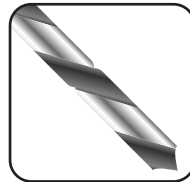

Bohrer:
2, 3, 4, 8 mm



Schraubendreher
(Torx)



Empfehlungen und Untergrundvorbereitungen

Der wichtigste Bestandteil des Beckens ist die Folienauskleidung.

Schwimmbadfolie ist ein thermoplastisches Material, das sich unter Einwirkung von Wärme ausdehnt bzw. bei Kälte zusammenzieht.

Die Auskleidung soll bei Temperaturen zwischen +15°C und +25°C eingebaut werden, da bei diesen Temperaturen die Folie am einfachsten zu handhaben ist.

Bei höheren Temperaturen besteht Gefahr, die Folie zu überdehnen. Bei zu niedriger Temperatur ist die Folie hart, unelastisch und fertigungsbedingte Legefalten lassen sich am Beckenboden schlecht ausgleichen. Generell muss die PVC-Innenhülle vor einer direkten Berührung mit dem Boden, der Betonbodenplatte und anderen PVC unverträglichen Materialien (z.B. Asphalt, Bitumen, Styropor) geschützt werden. Wir empfehlen hierzu unser Bodenschutzvlies.

Der Untergrund sollte hart, glatt und eben sein.

Wir empfehlen eine Betonplatte als Aufstellfläche für Ihren Pool. Mit einer Baustahlmatte armiert, ist eine Dicke von ca. 10 cm ausreichend. Darauf steht das Becken sicher, der Rand kann nicht einsinken und der Boden ist immer glatt zur Reinigung.

Aufgeschüttete Böden sind nicht geeignet. In solchen Fällen ist ein Baufachmann oder ein Statiker zu befragen. Achten Sie bitte darauf, dass Sie nicht in den Grundwasserbereich kommen.

Alternativ zur Bodenbetonplatte, empfehlen wir unser conZero System. Bitte beachten Sie die gesonderte Aufbauanleitung dieses Systems, in Bezug auf die Vorbereitungen des Untergrundes.



Bitte kontrollieren Sie vor dem Aufbau des Holzpools die Lieferung auf Vollständigkeit.

WANDBRETT - W

	W1 x70 L: 1772 mm B: 145 mm T: 45 mm		W2 x3 L: 1772 mm B: 135 mm T: 45 mm
	W3 x4 L: 1772 mm B: 78 mm T: 45 mm		W4 x4 L: 1772 mm B: 67 mm T: 45 mm
	W5 x1 L: 1772 mm B: 135 mm T: 45 mm		W6 x1 L: 1772 mm B: 145 mm T: 45 mm
	W7 x1 L: 1772 mm B: 145 mm T: 45 mm		

TREPPE - T



	T1 x1 L: 1621 mm B: 145 mm T: 28 mm
	T2 x1 L: 1621 mm B: 145 mm T: 28 mm
	T3 x4 L: 440 mm B: 145 mm T: 28 mm

KONSOLEN - K

	K1 x10 L: 245 mm B: 145 mm T: 45 mm
	K2 x8 L: 245 mm B: 145 mm T: 45 mm
	K3 x4 L: 180 mm B: 145 mm T: 45 mm

STÜCKLISTE

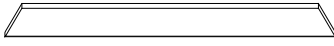

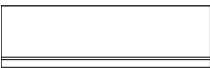



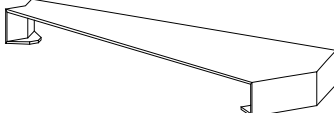



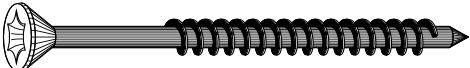

BRETTER FÜR HOLZDECK - D

	D1 x7 L: 1669 mm B: 145 mm T: 28 mm		D2 x8 L: 1545 mm B: 145 mm T: 28 mm
	D3 x1 L: 657 mm B: 145 mm T: 28 mm		D4 x1 L: 657 mm B: 145 mm T: 28 mm
	D5 x1 L: 350 mm B: 145 mm T: 28 mm		

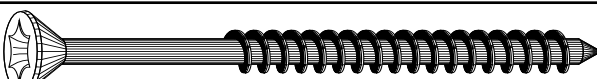
ECKKLEISTEN - E

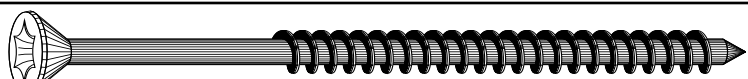
	E1 x16 L: 1320 mm B: 60 mm T: 28 mm		E2 x8
---	---	--	--------------

SCHRAUBEN UND SCHARNIERE - S

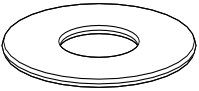
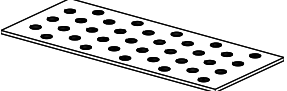
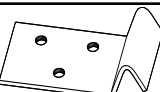
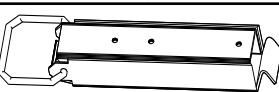
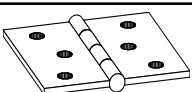
	S1 3,0 x 25 mm  x44		S2 3,5 x 25 mm  x226		S3 4,5 x 60 mm  x59
	S4 5 x 80 mm  x32		S5 5 x 100 mm  x56		
	S6 4 x 40 mm  x64		S7 Unterlegscheibe x32		S8 Lochblech x18
	S9 x2		S10 x2		S11 x2

STÜCKLISTE

ZUBEHÖR - Z

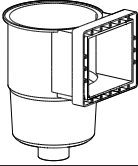
	Skimmer Set	Z1 x1
---	-------------	--------------

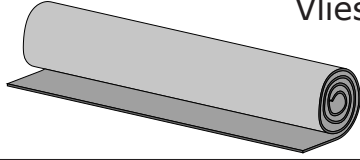
	Vlies	Z2 x1
--	-------	--------------

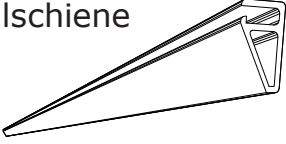
	Profilschiene	Z3 x10 L: 1250mm
---	---------------	----------------------------

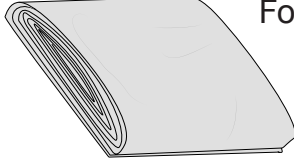
	Folie	Z4 x1
--	-------	--------------

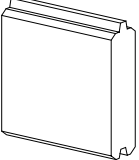
	Schlagbrett	Z5 x1
---	-------------	--------------

Z6 x1	Edelstahl Leiter [OPTIONAL]
--------------	-----------------------------

	Teflonband	x1 L: 12 m B: 12 mm
--	------------	---------------------------

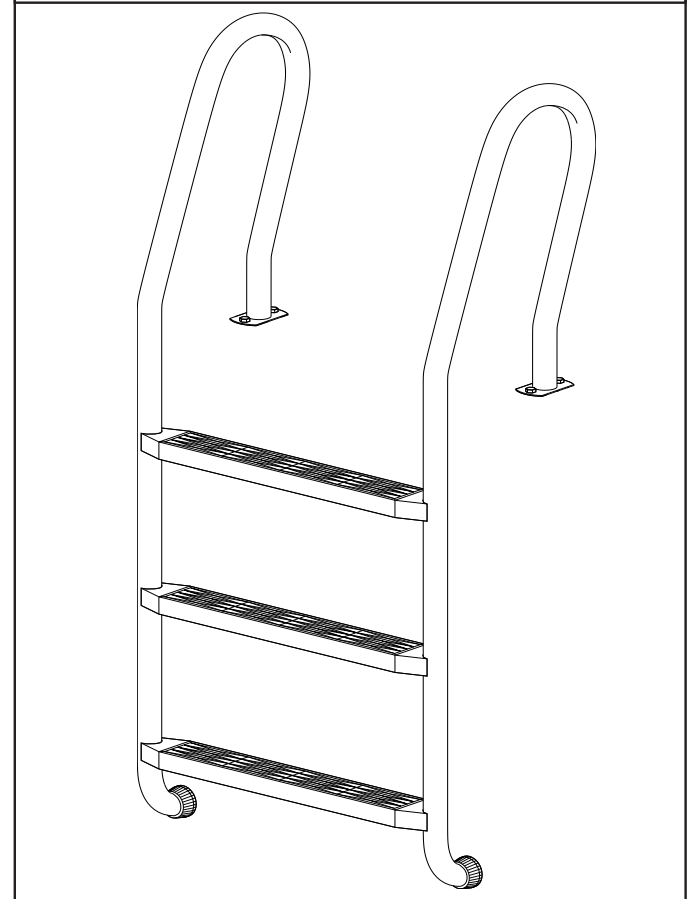

	Klebeband	x1 L: 66 m B: 60 mm
---	-----------	---------------------------

	Sprühkleber	x1
---	-------------	----

1. AUFBAU DER WAND - TEIL 1- ÜBERSICHT

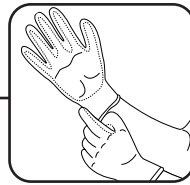
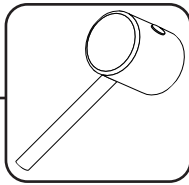
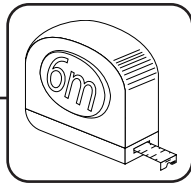
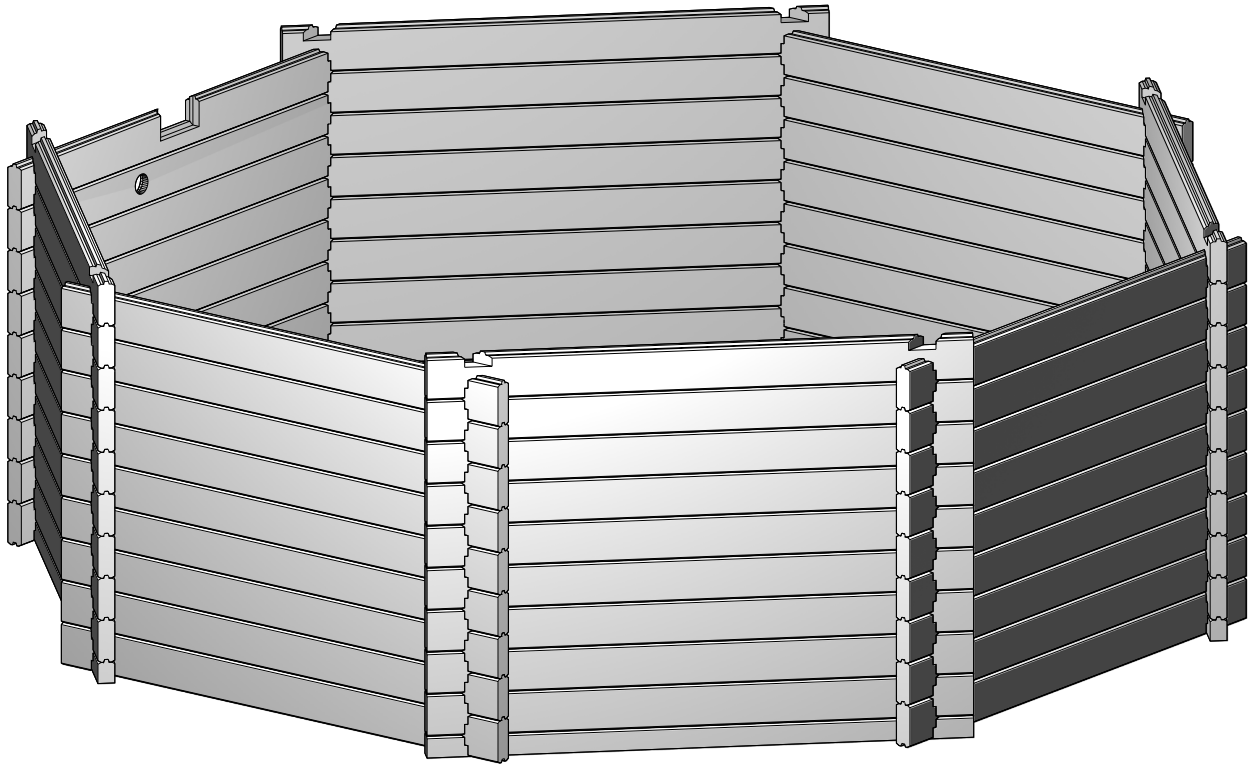

BENÖTIGTE TEILE FÜR DIESEN SCHRITT

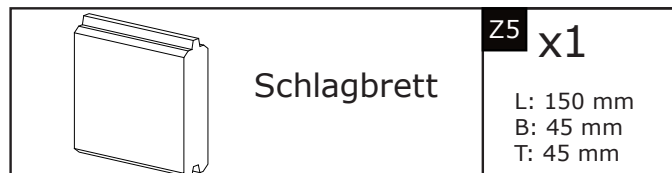
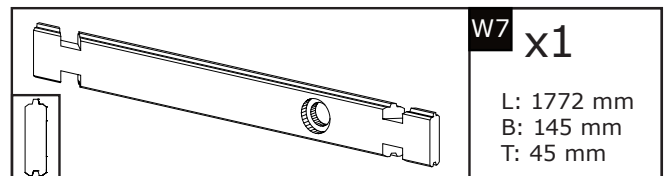
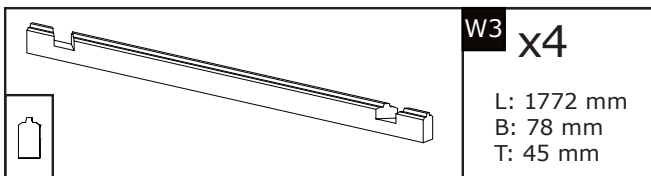
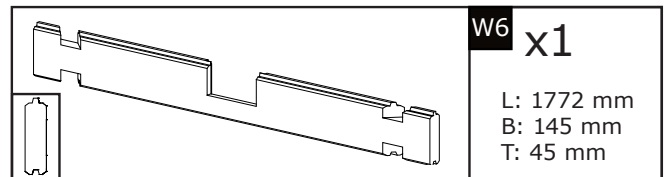
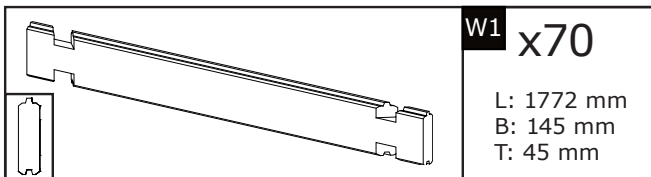

1. AUFBAU DER WAND - TEIL 1 - ÜBERSICHT

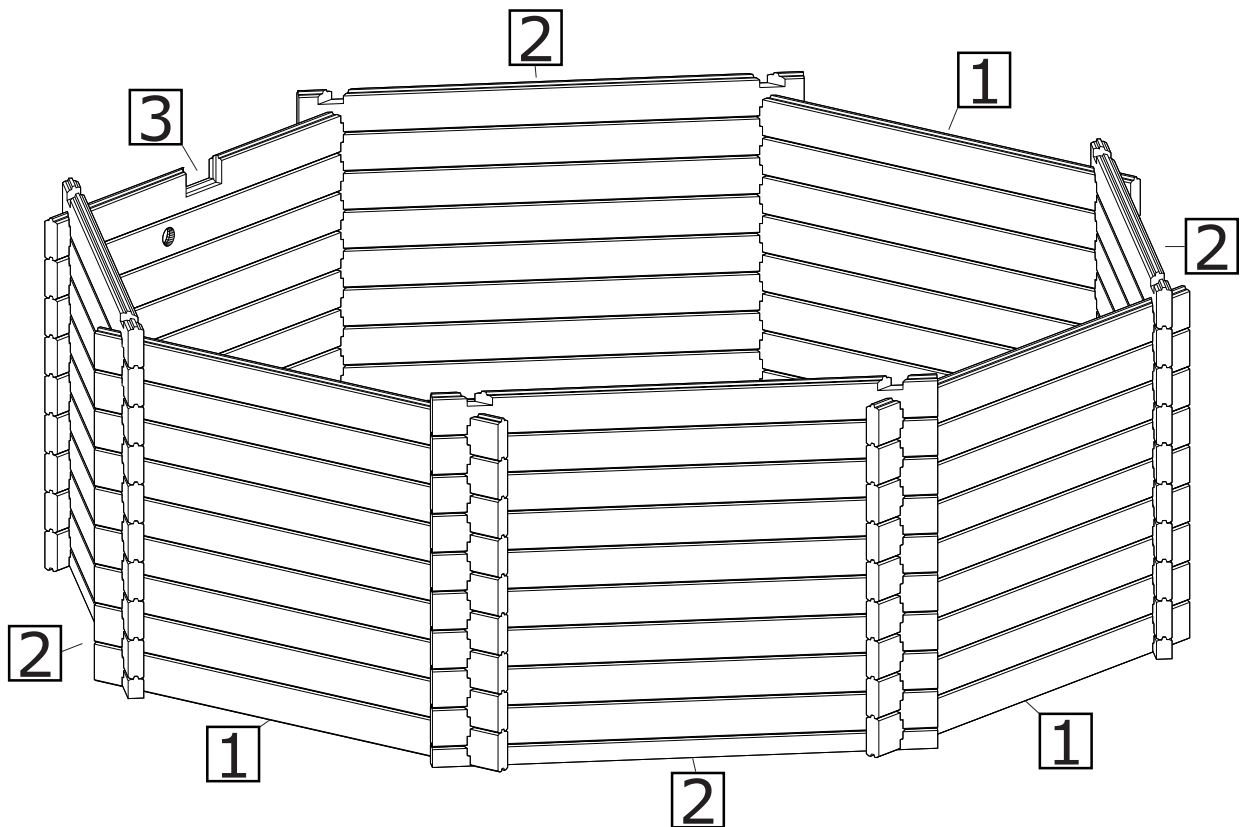
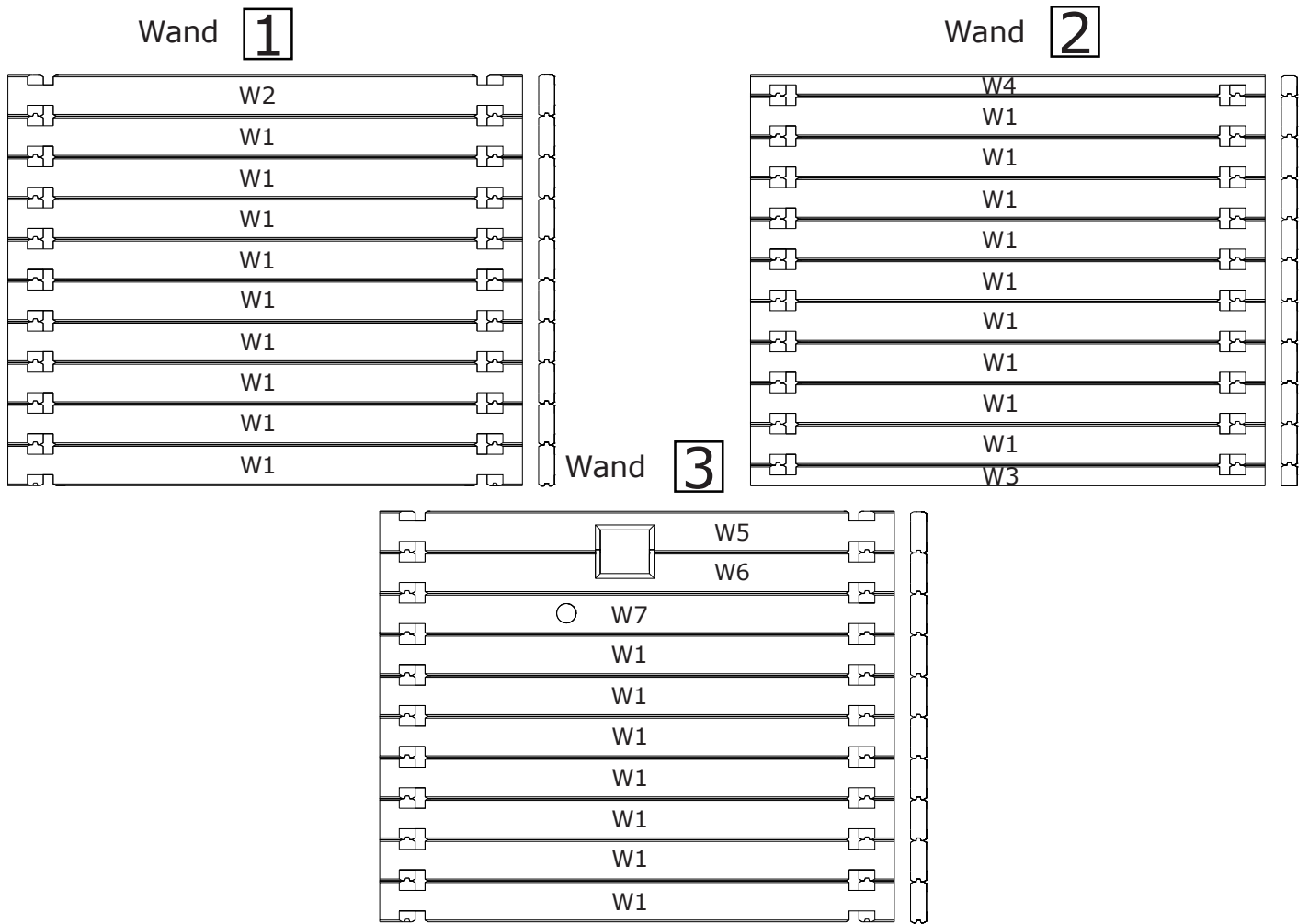

1. AUFBAU DER WAND - TEIL 1

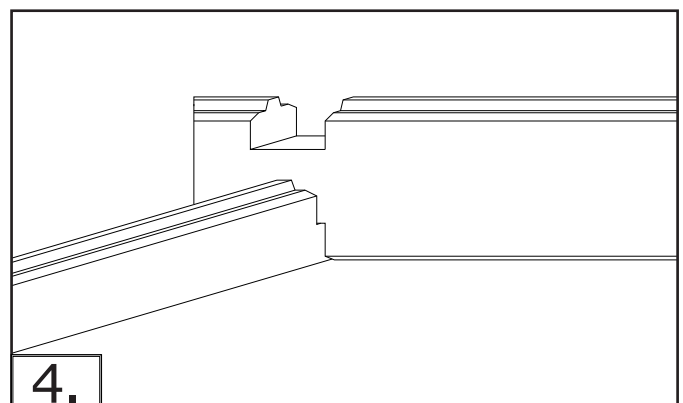
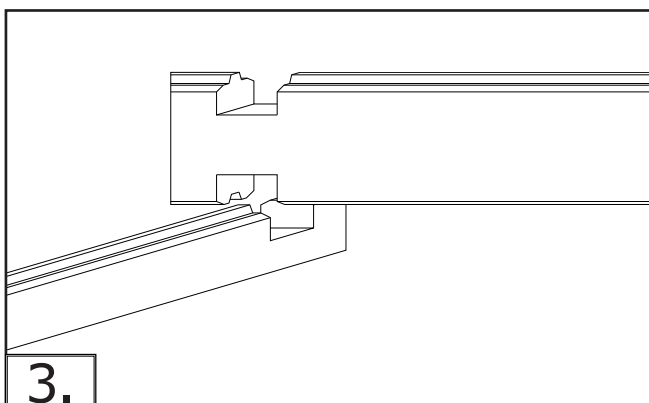
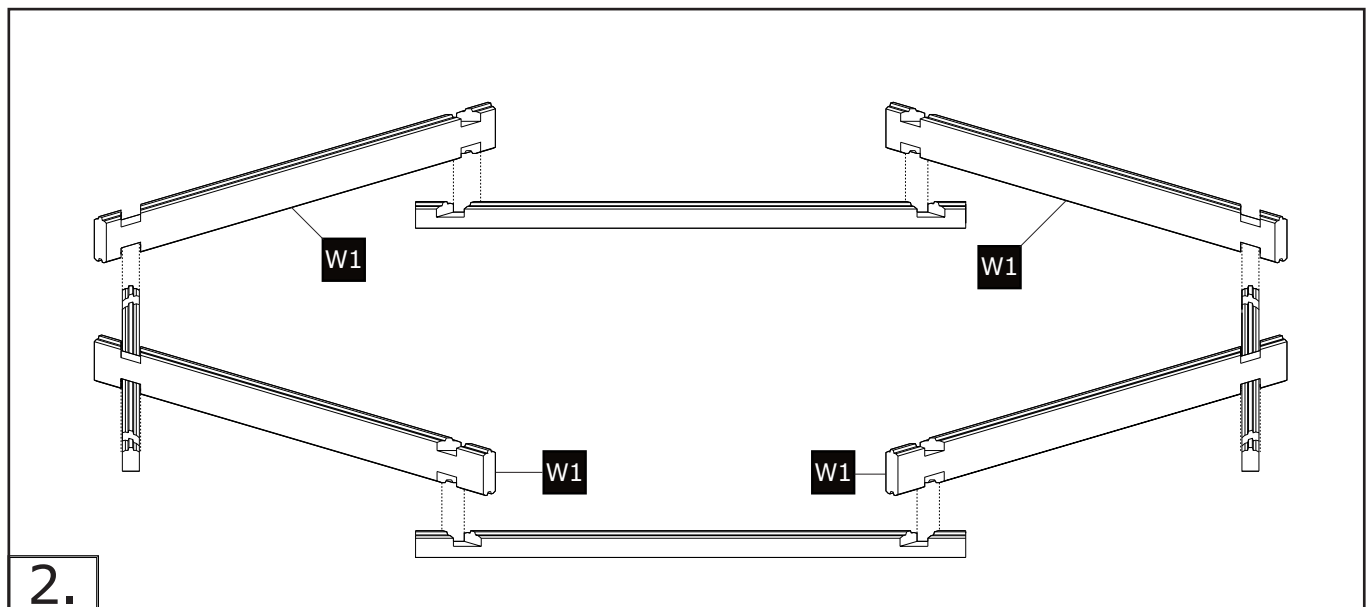
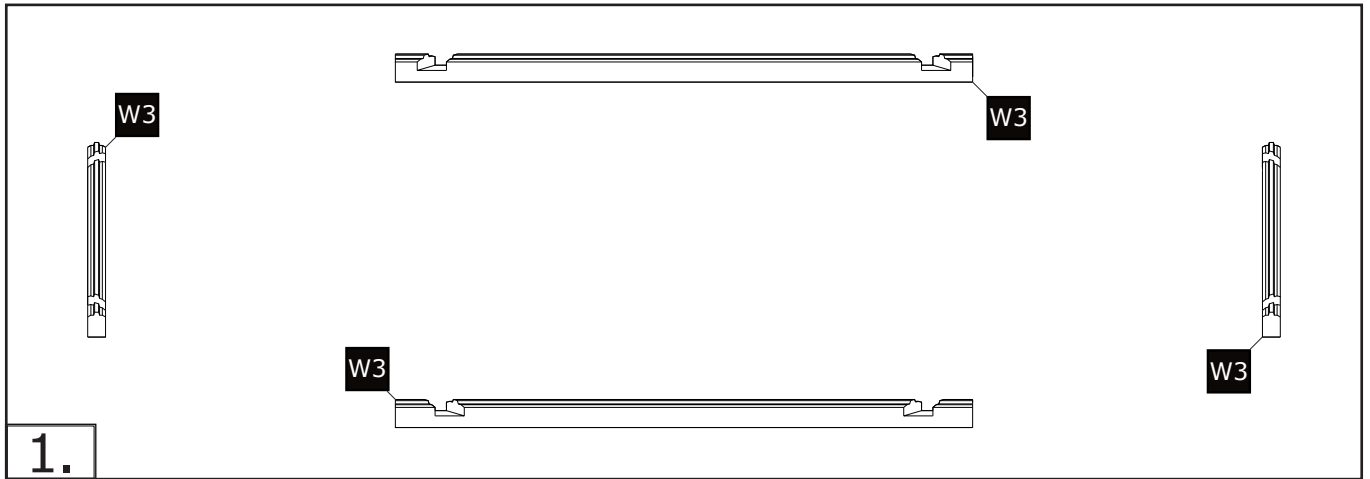

1. AUFBAU DER WAND - TEIL 1

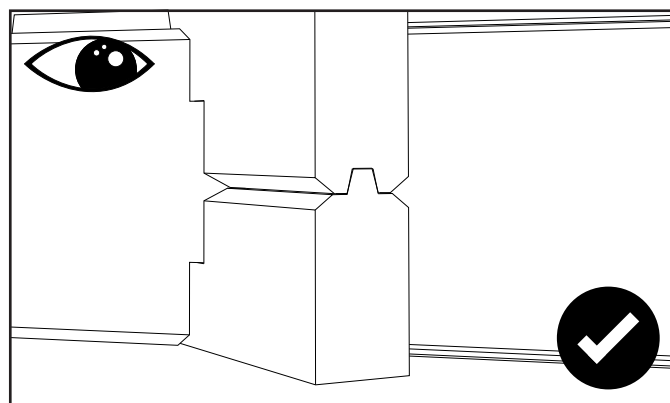
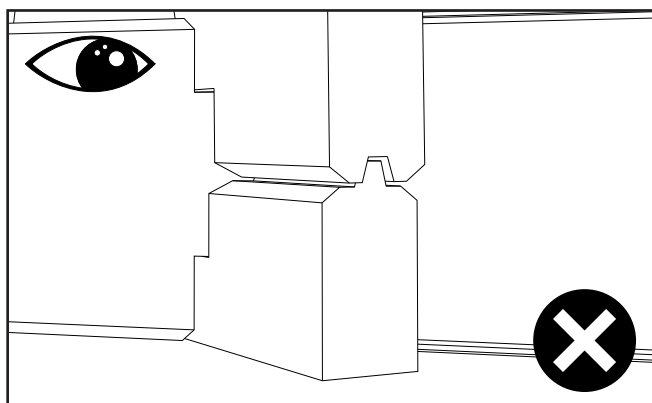
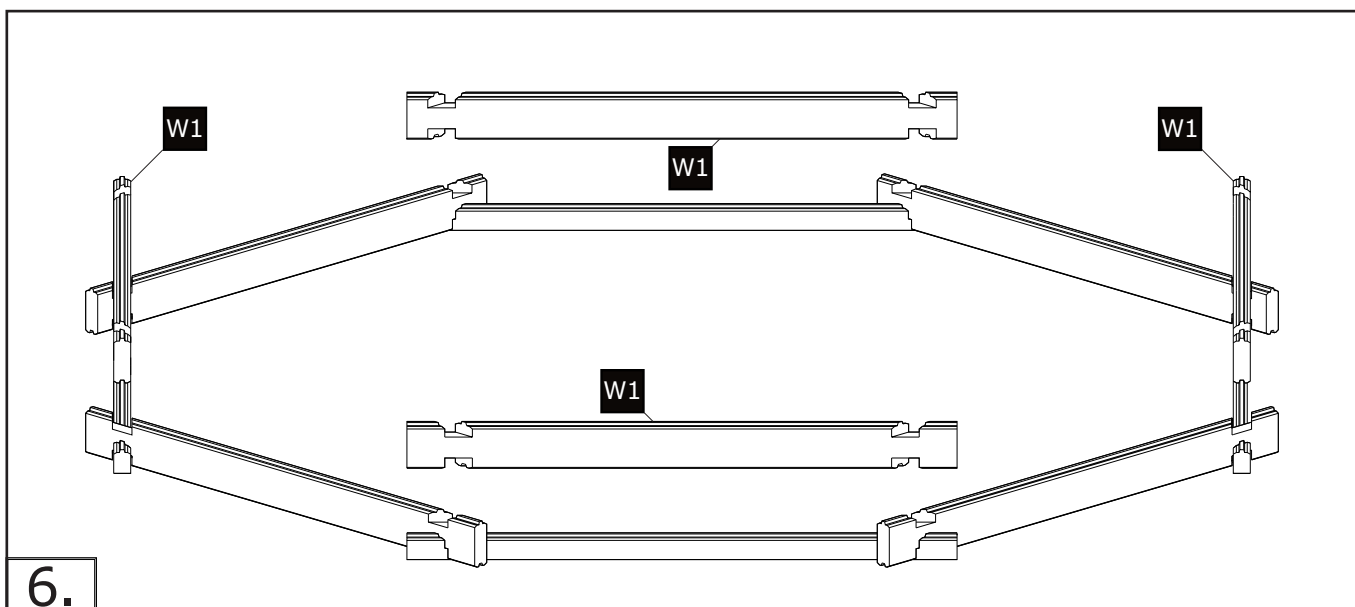
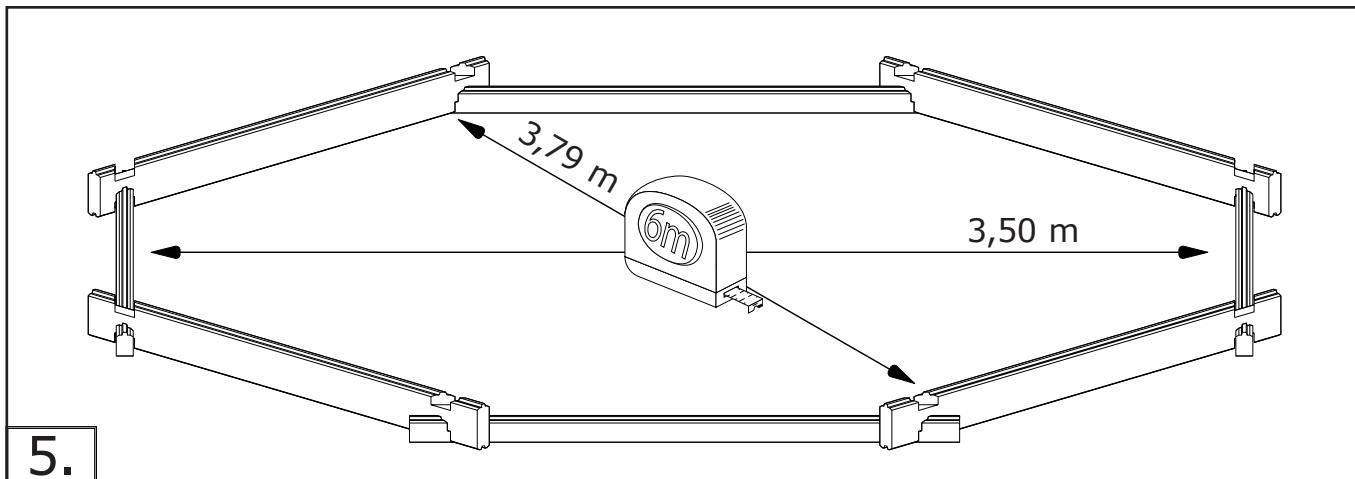

1. AUFBAU DER WAND - TEIL 1

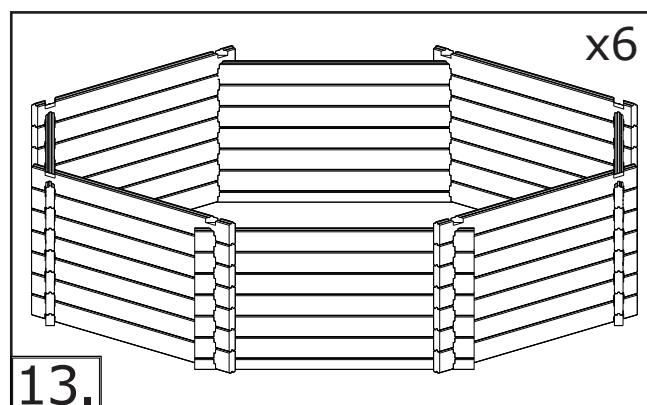
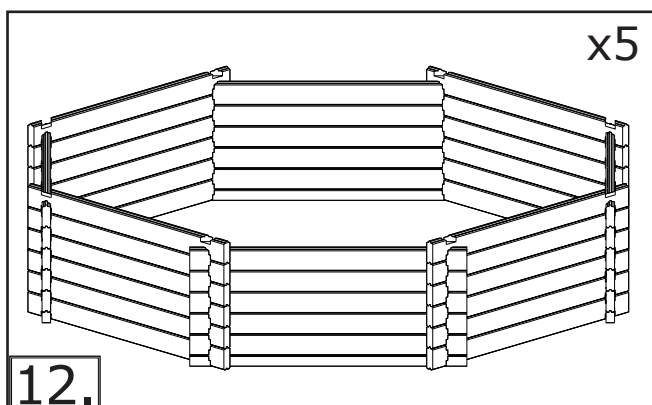
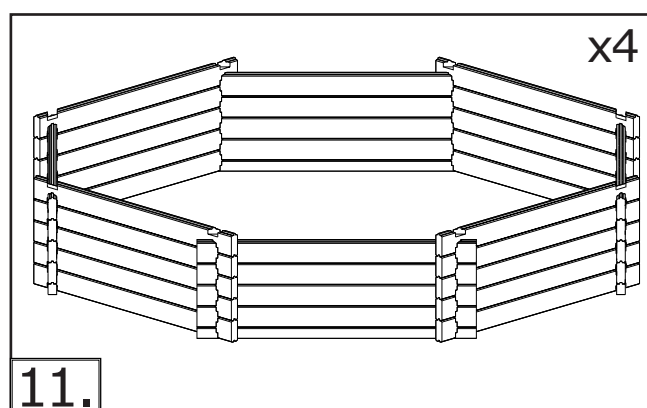
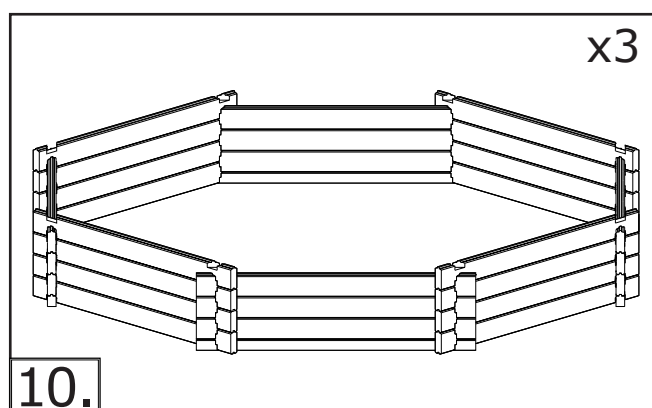
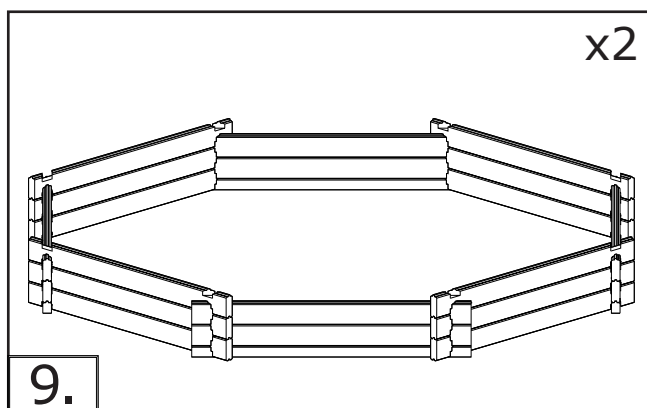
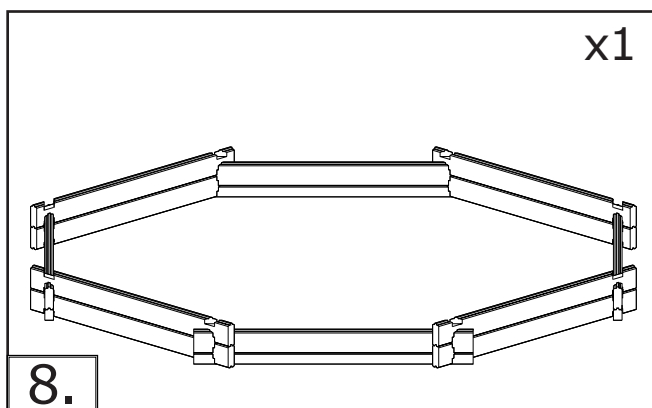
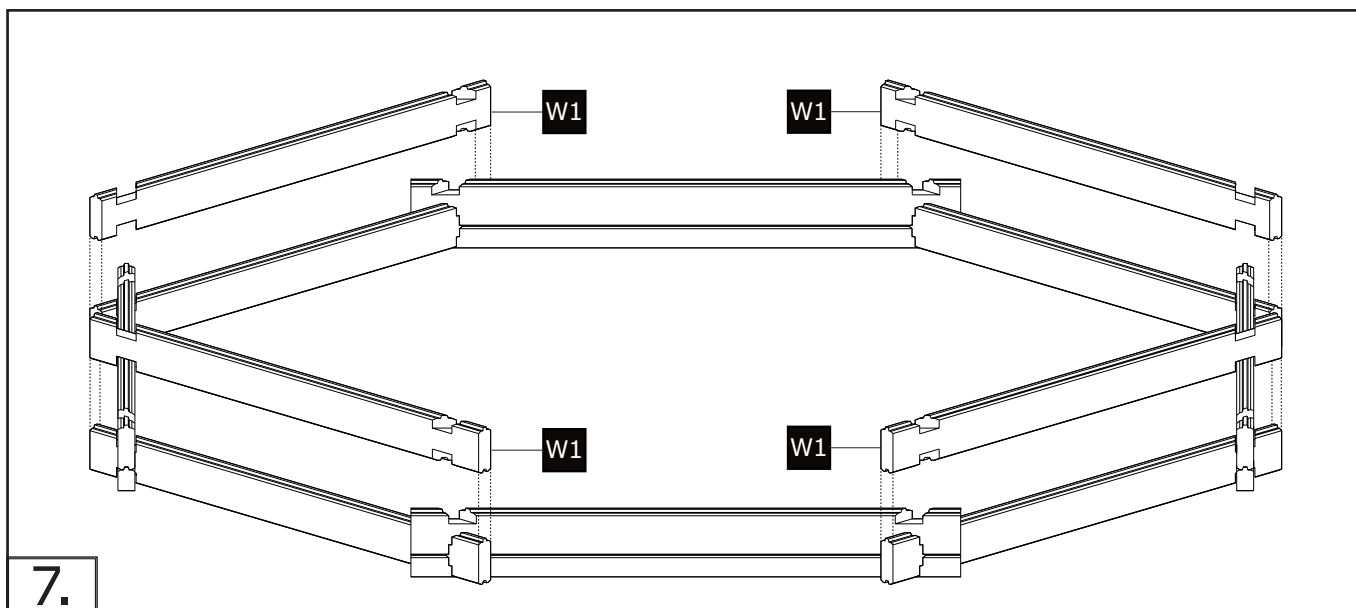

1. AUFBAU DER WAND - TEIL 1

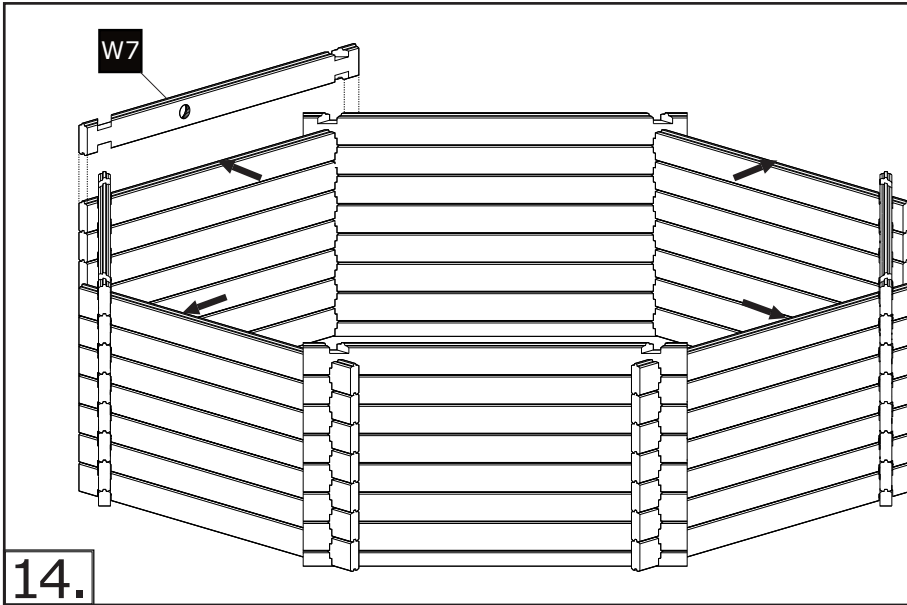

Wählen Sie jetzt die gewünschte Position von Skimmer und Einlaufdüse.

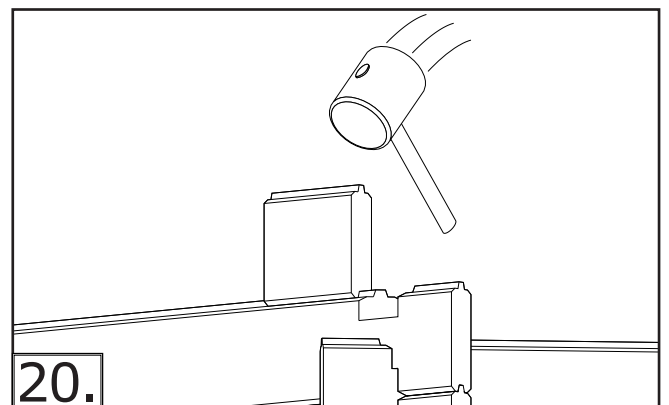
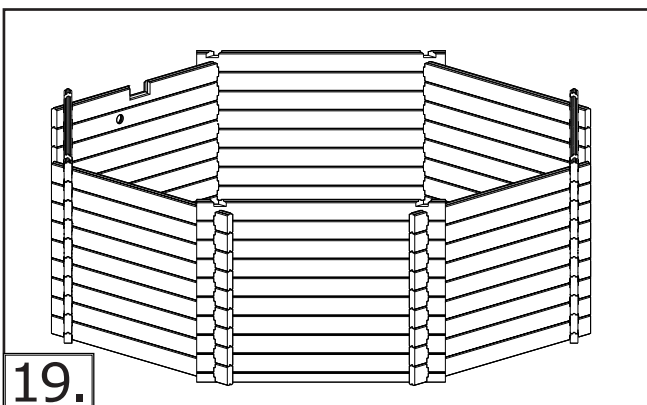
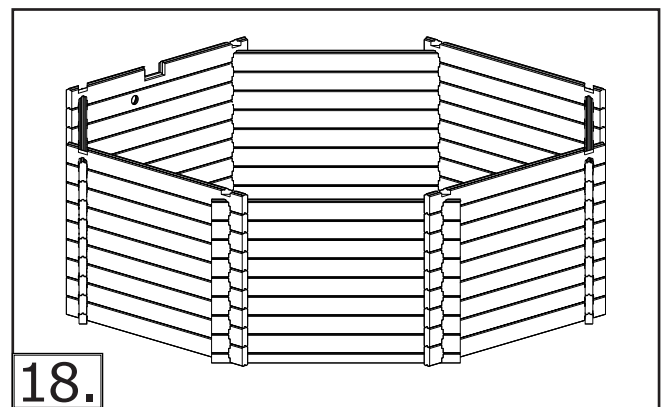
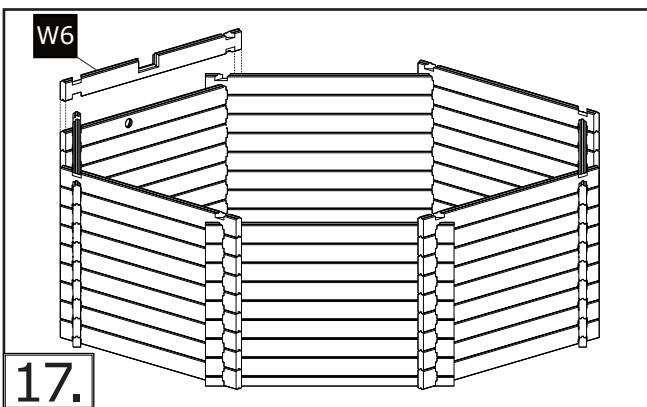
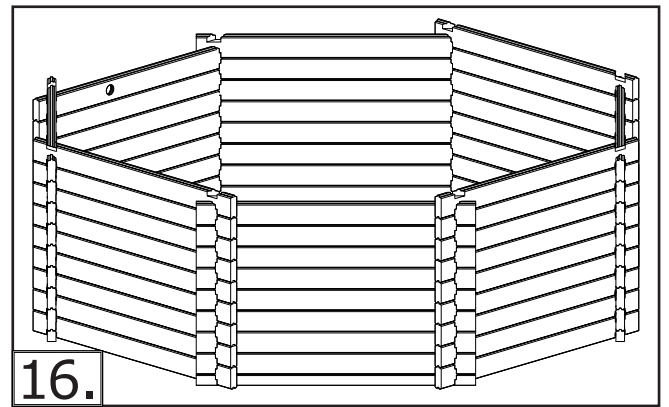
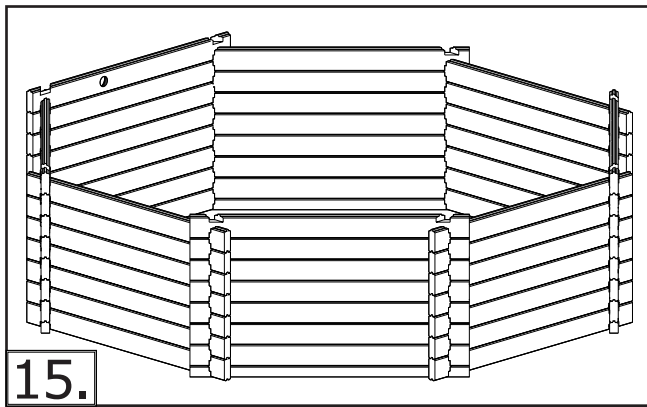

2. AUFBAU DER WAND - TEIL 2 - ÜBERSICHT

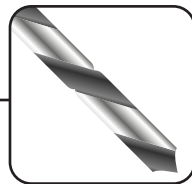
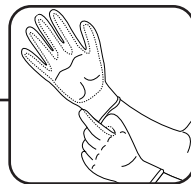
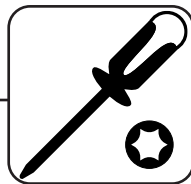
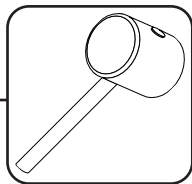
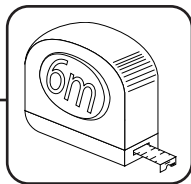
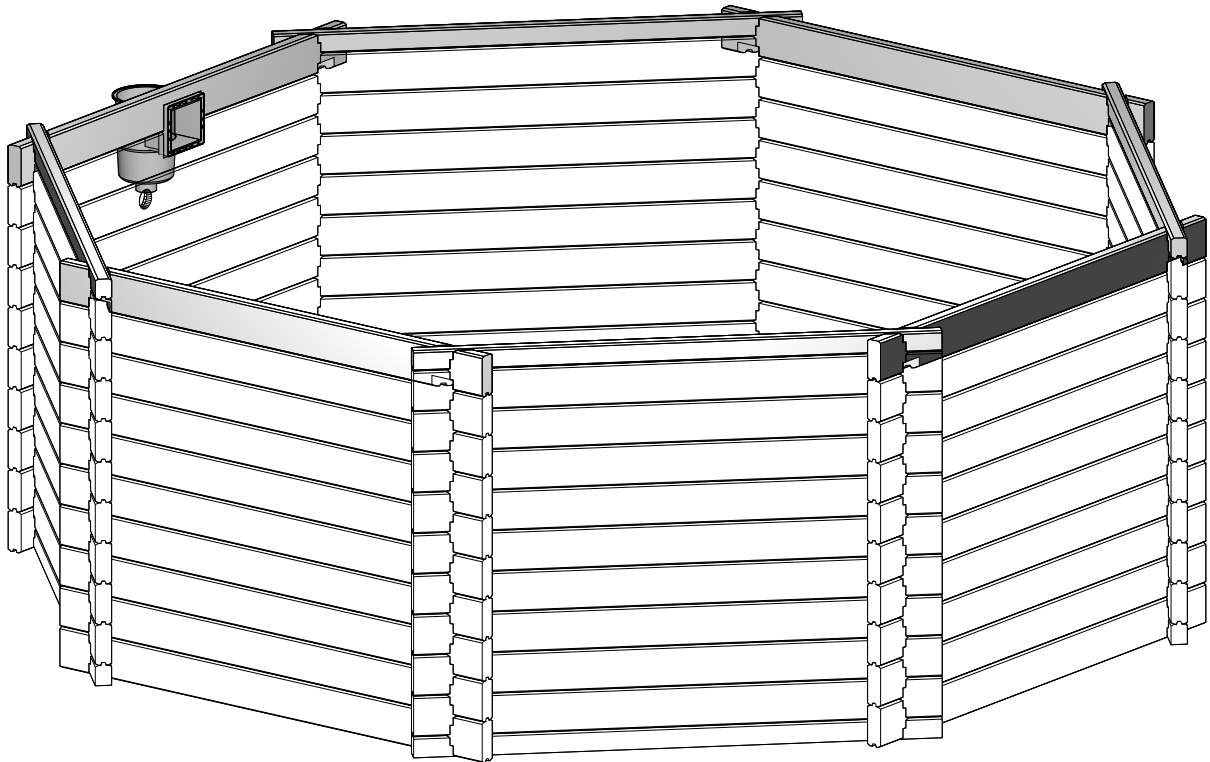

BENÖTIGTE TEILE FÜR DIESEN SCHRITT

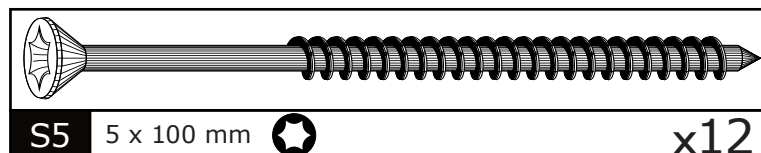
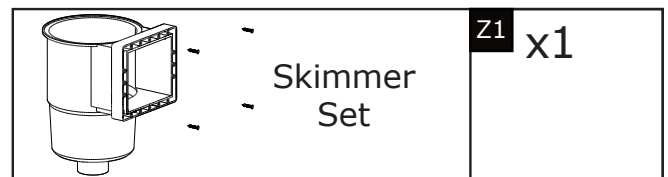
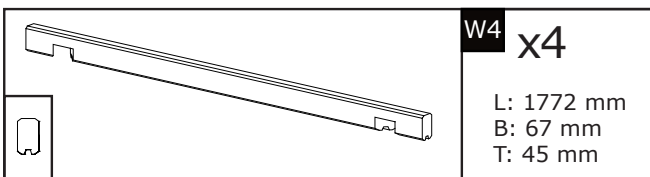
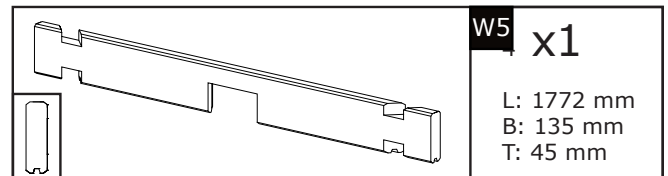
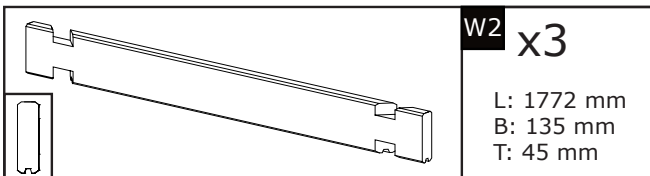

2. AUFBAU DER WAND - TEIL 2

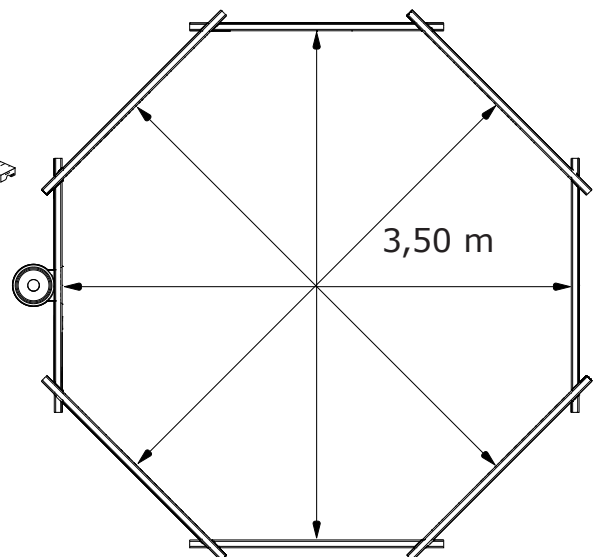
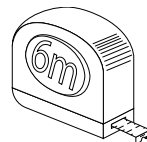
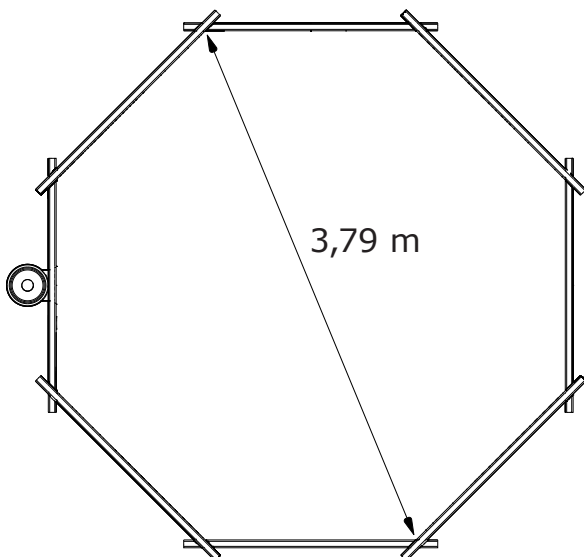
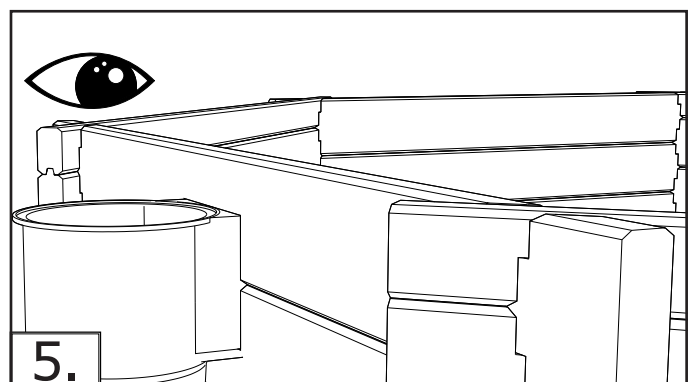
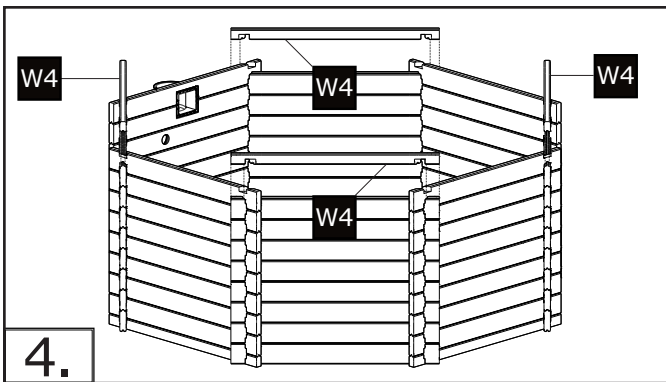
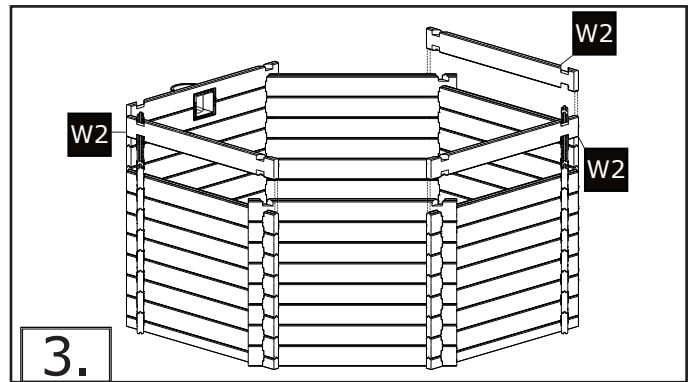
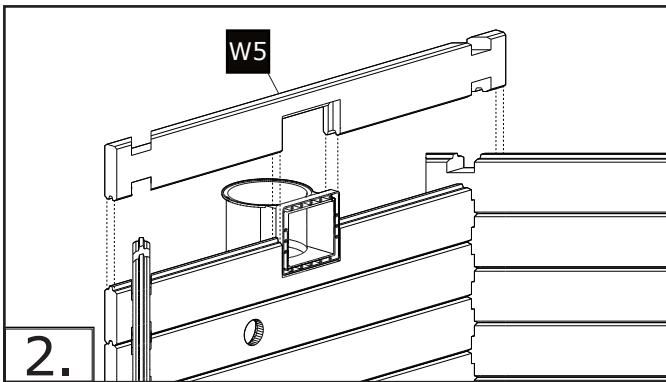
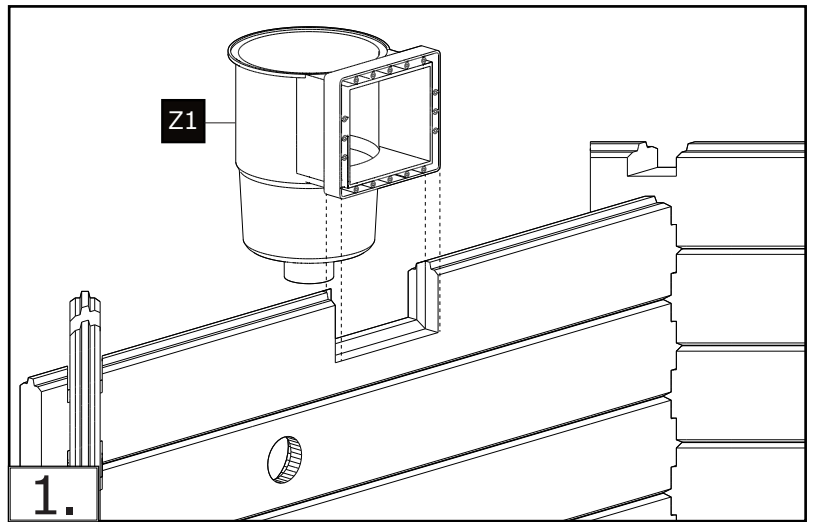
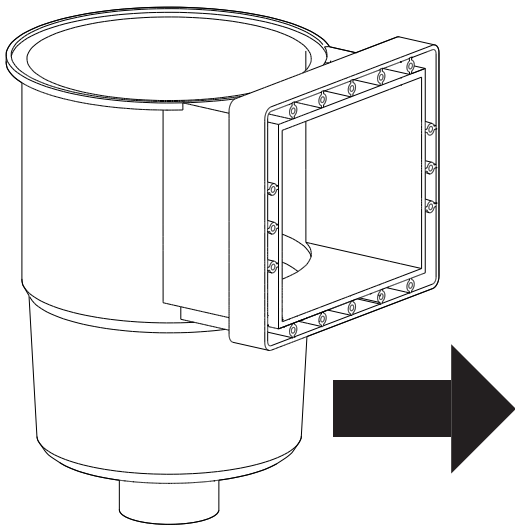

2. AUFBAU DER WAND - TEIL 2

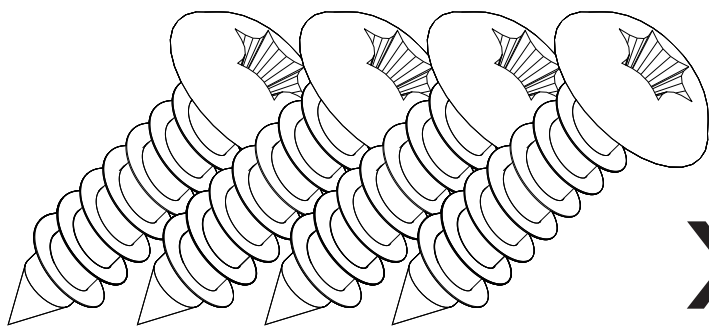
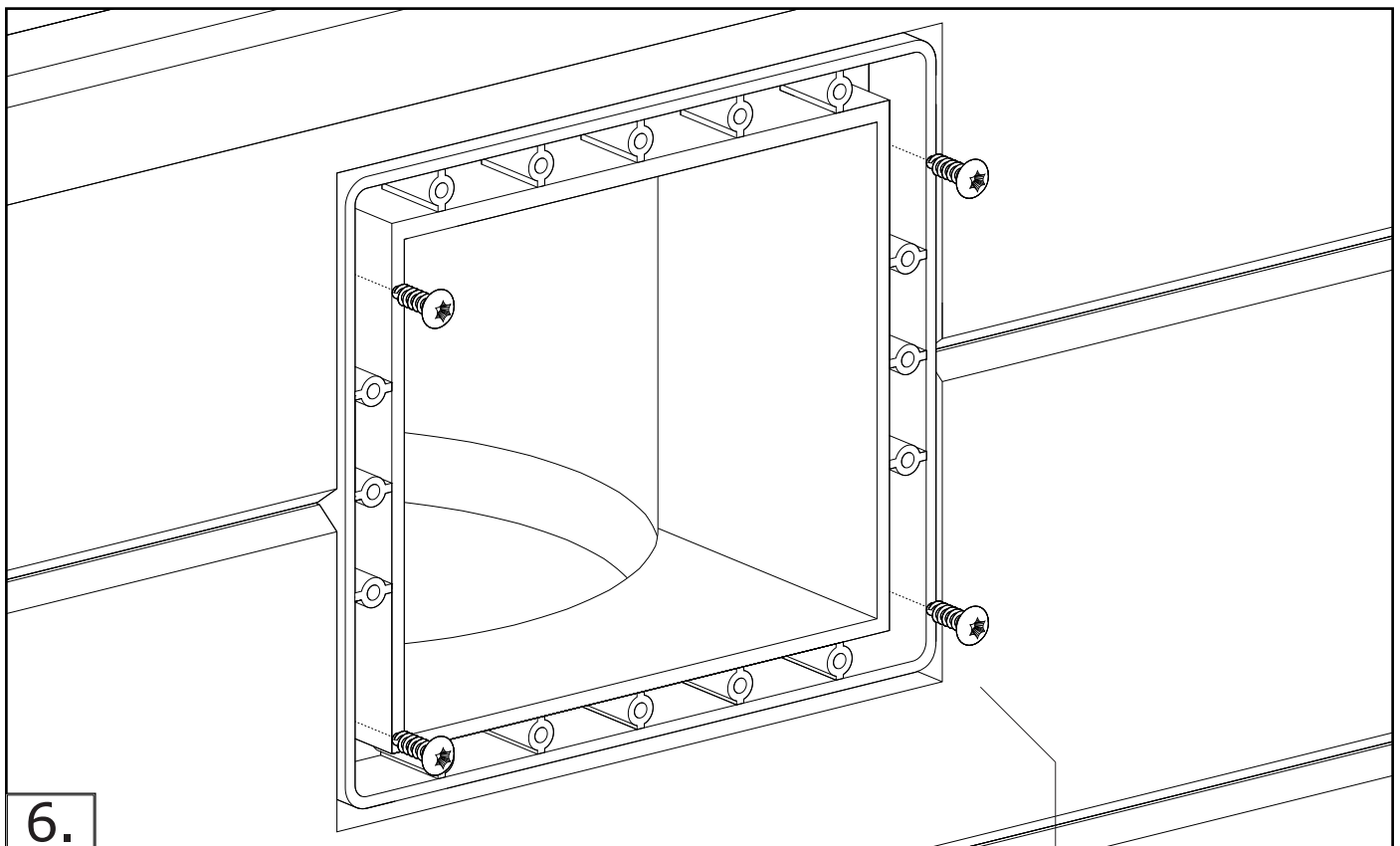

x4

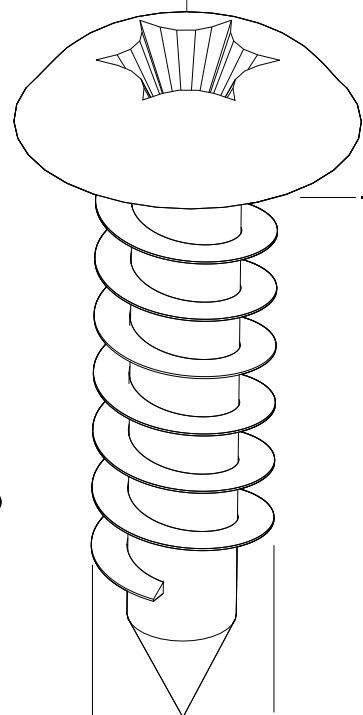
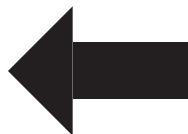
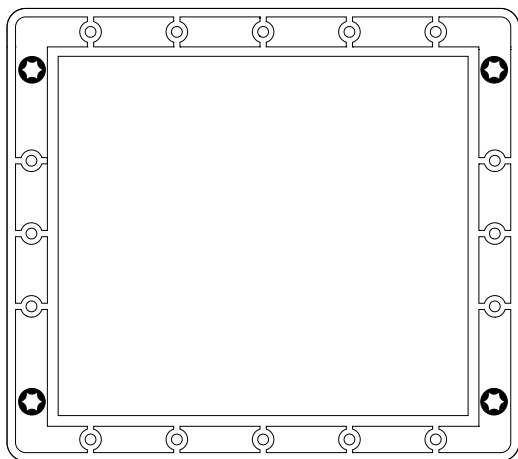

16 mm

3,5 mm

2. AUFBAU DER WAND - TEIL 2

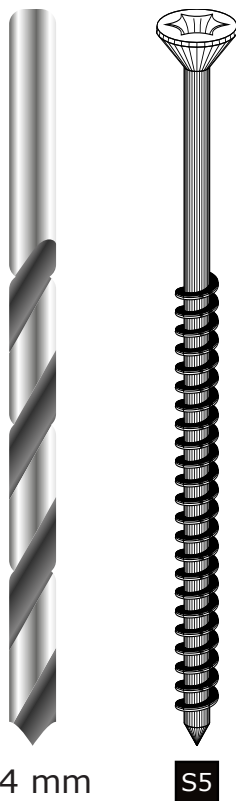

Schrauben Sie die **W4** Bretter an die darunter liegenden Wandbohlen mit einem Abstand von ca. 50 cm

6.



- Alle Teile aus Holz müssen, vor dem Einsetzen der Schrauben, immer vorgebohrt werden. Wenn diese Vorsichtsmaßnahme nicht befolgt wird, ist das Risiko einer Beschädigung des Holzes sehr hoch.

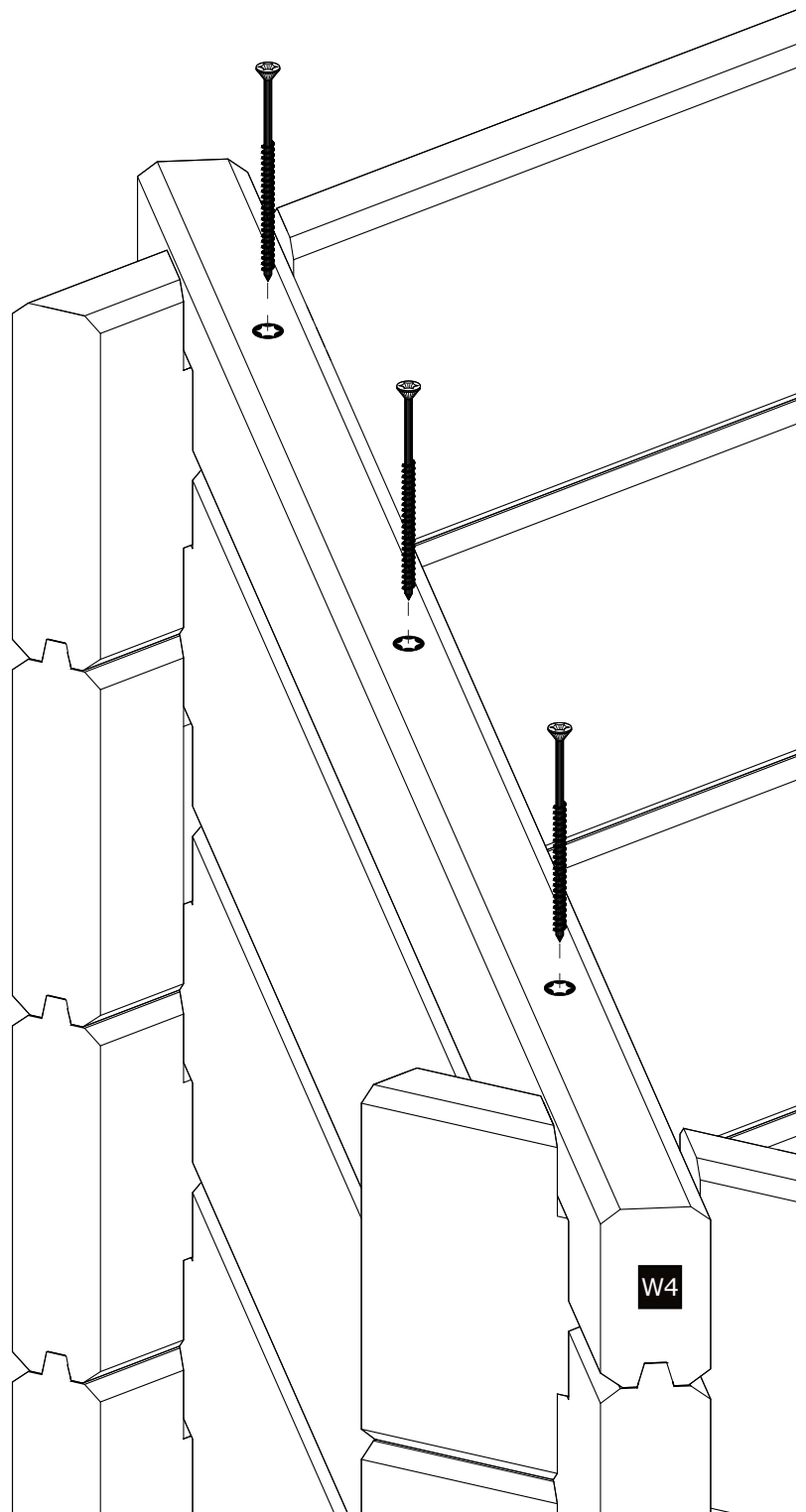

3. MONTAGE DER WANDLEISTE - ÜBERSICHT

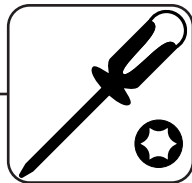
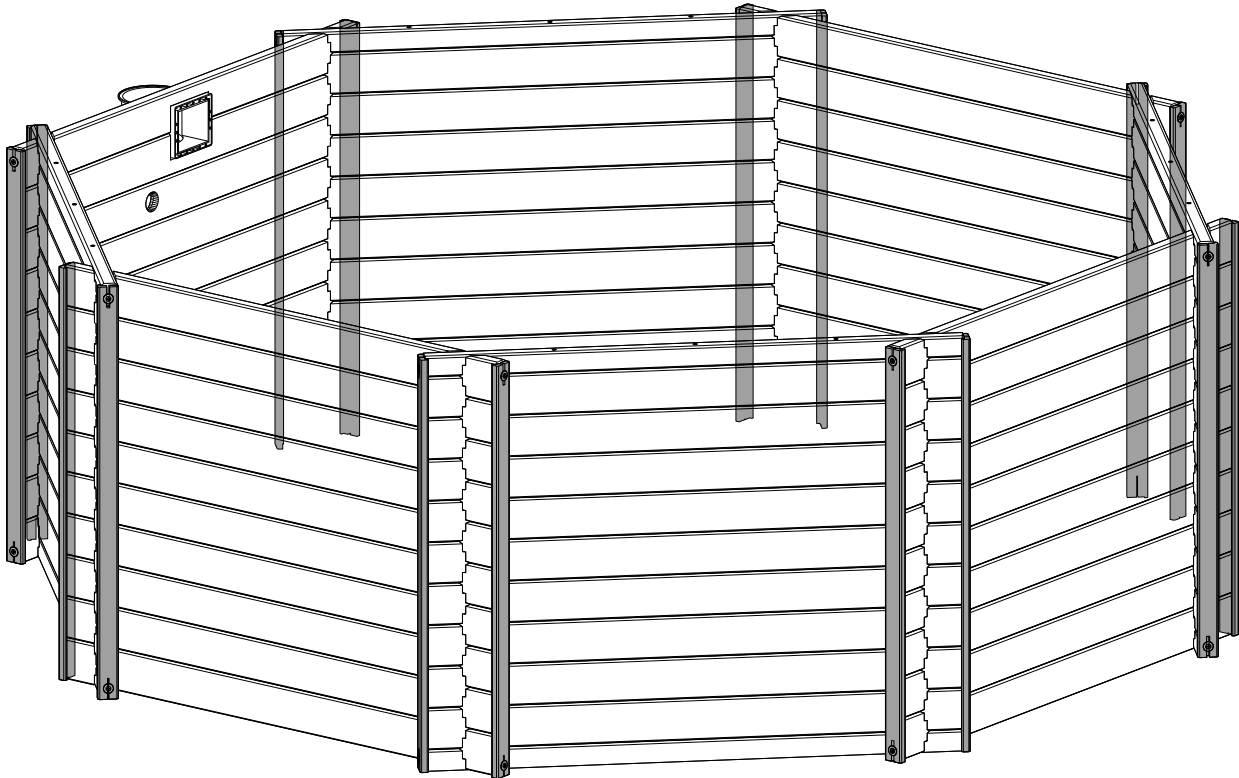

BENÖDIGTE TEILE FÜR DIESEN SCHRITT

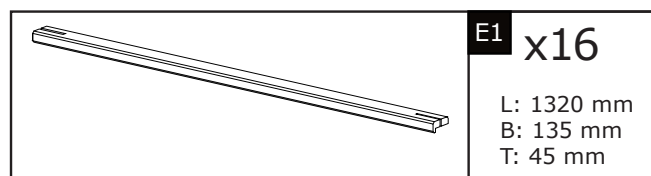
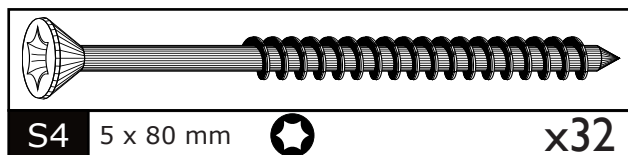

3. MONTAGE DER WANDLEISTE

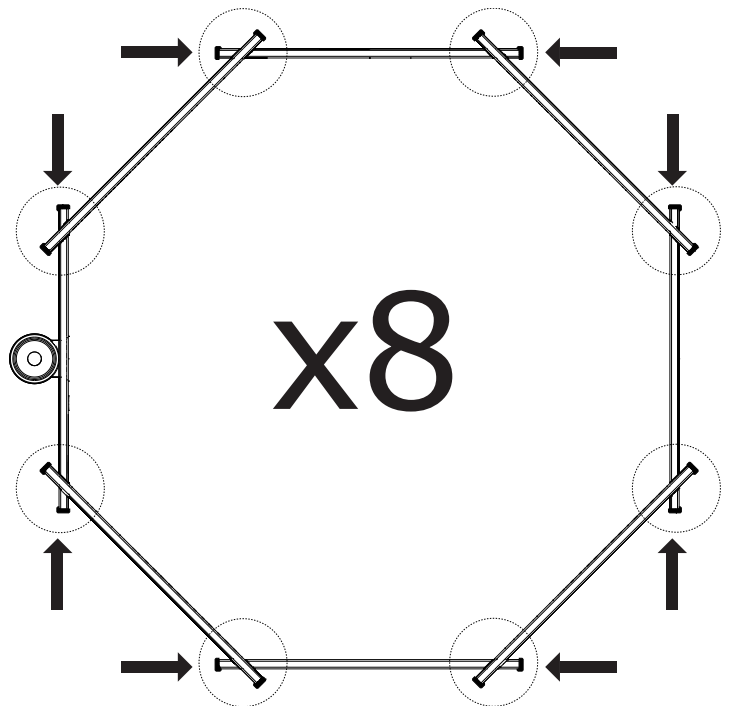
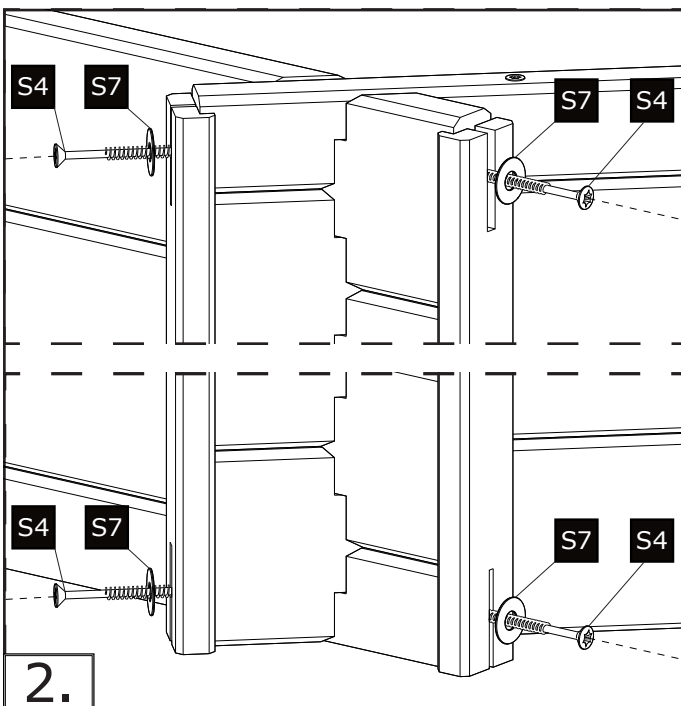
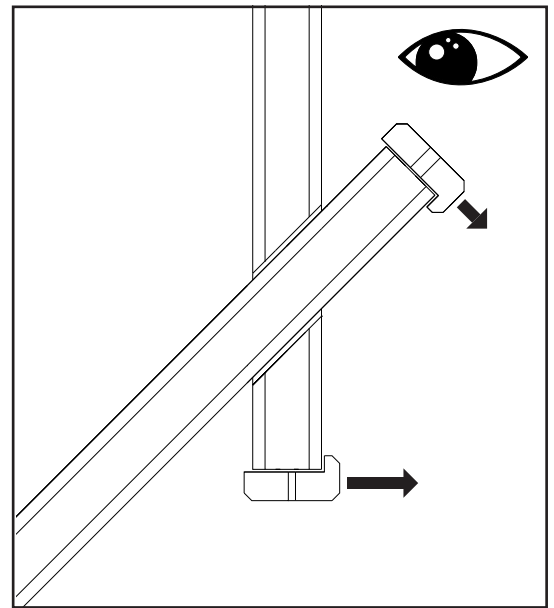
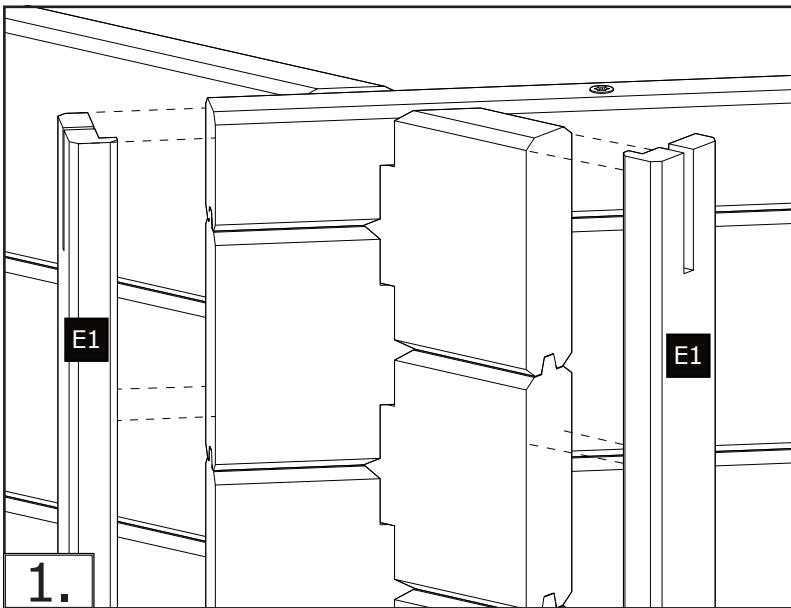

- Die Schrauben für die Eckleisten nicht fest anziehen.

- Die Wandbohlen müssen sich, durch unterschiedliche Temperaturen, ausdehnen und zusammen ziehen können.

4. MONTAGE DER KONSOLEN - ÜBERSICHT

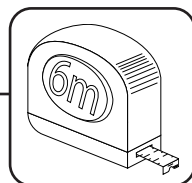
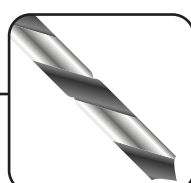
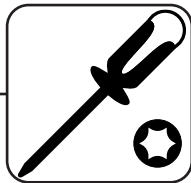
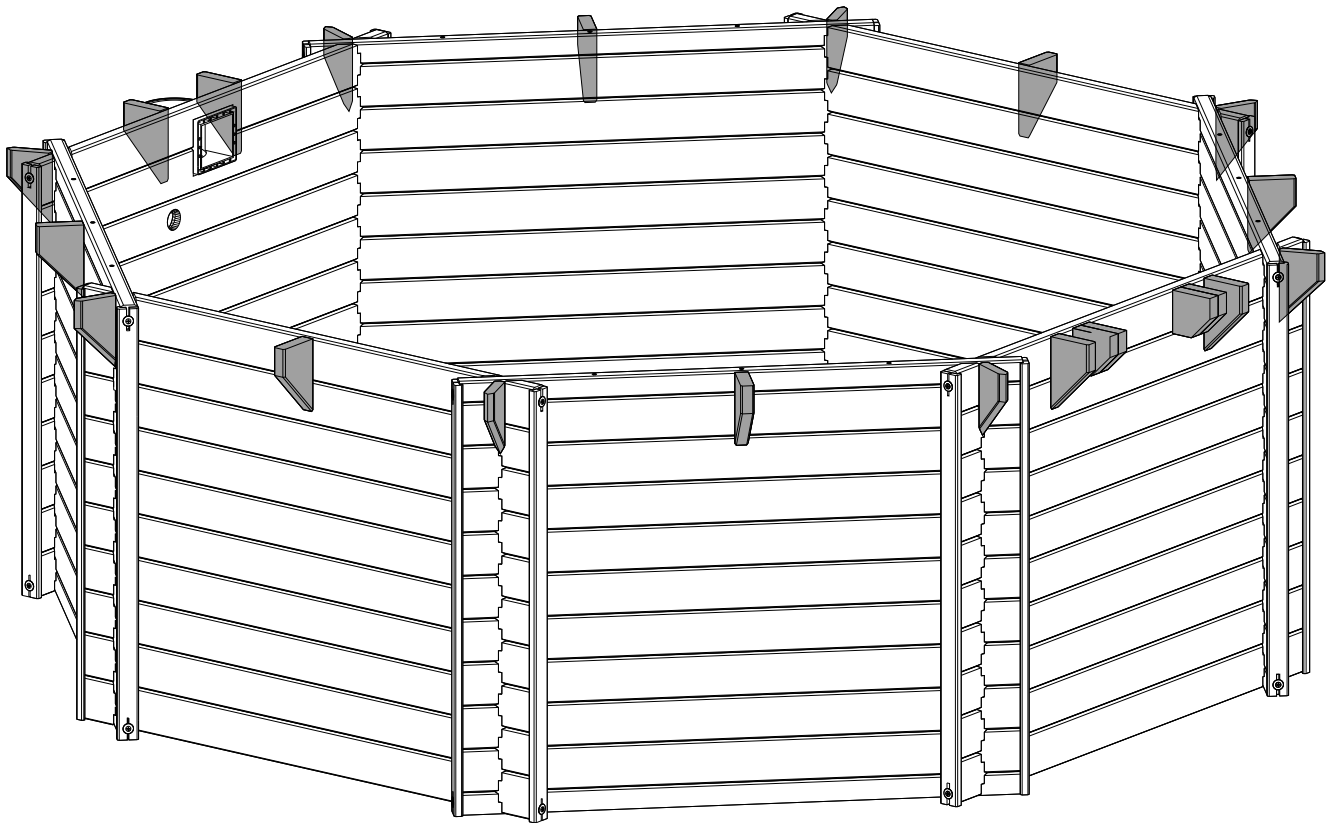

BENÖTIGTE TEILE FÜR DIESEN SCHRITT

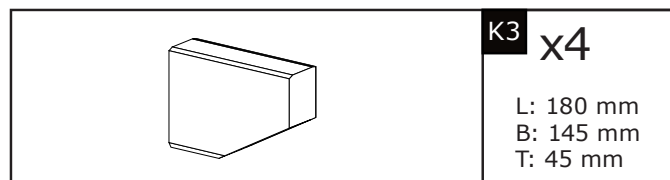
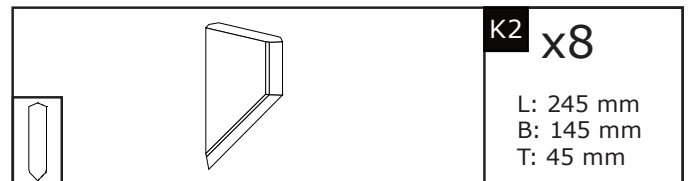
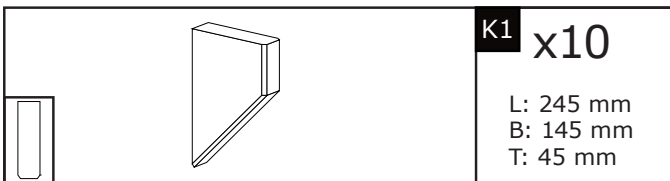
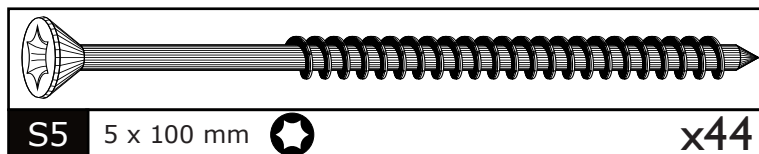

4. MONTAGE DER KONSOLEN

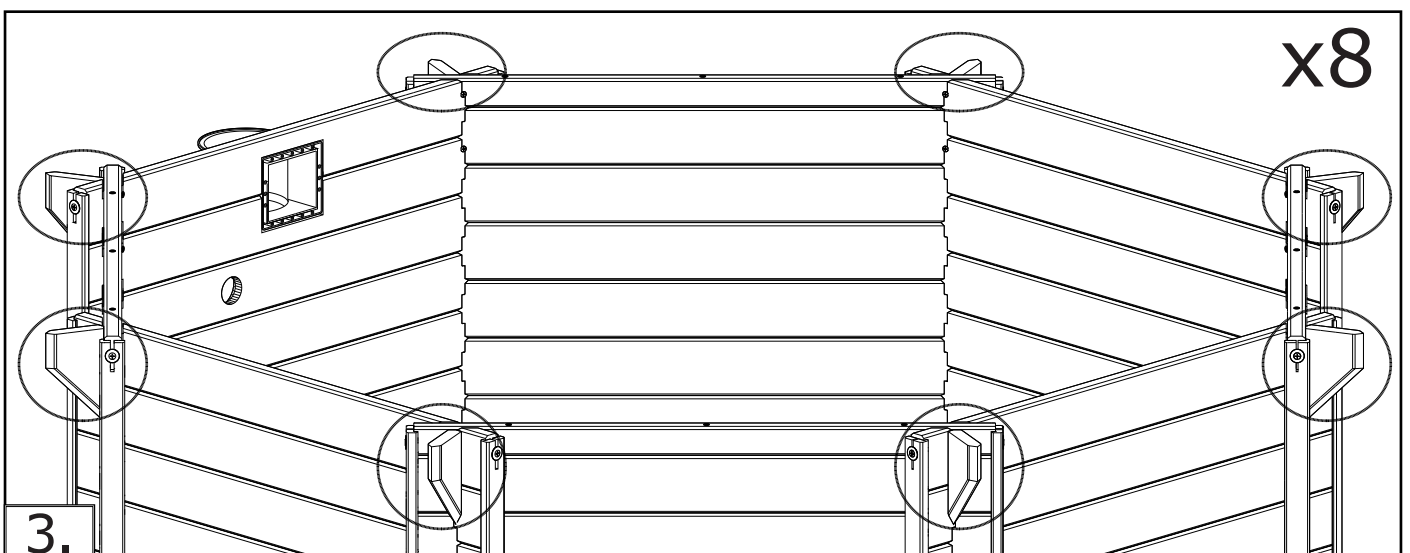
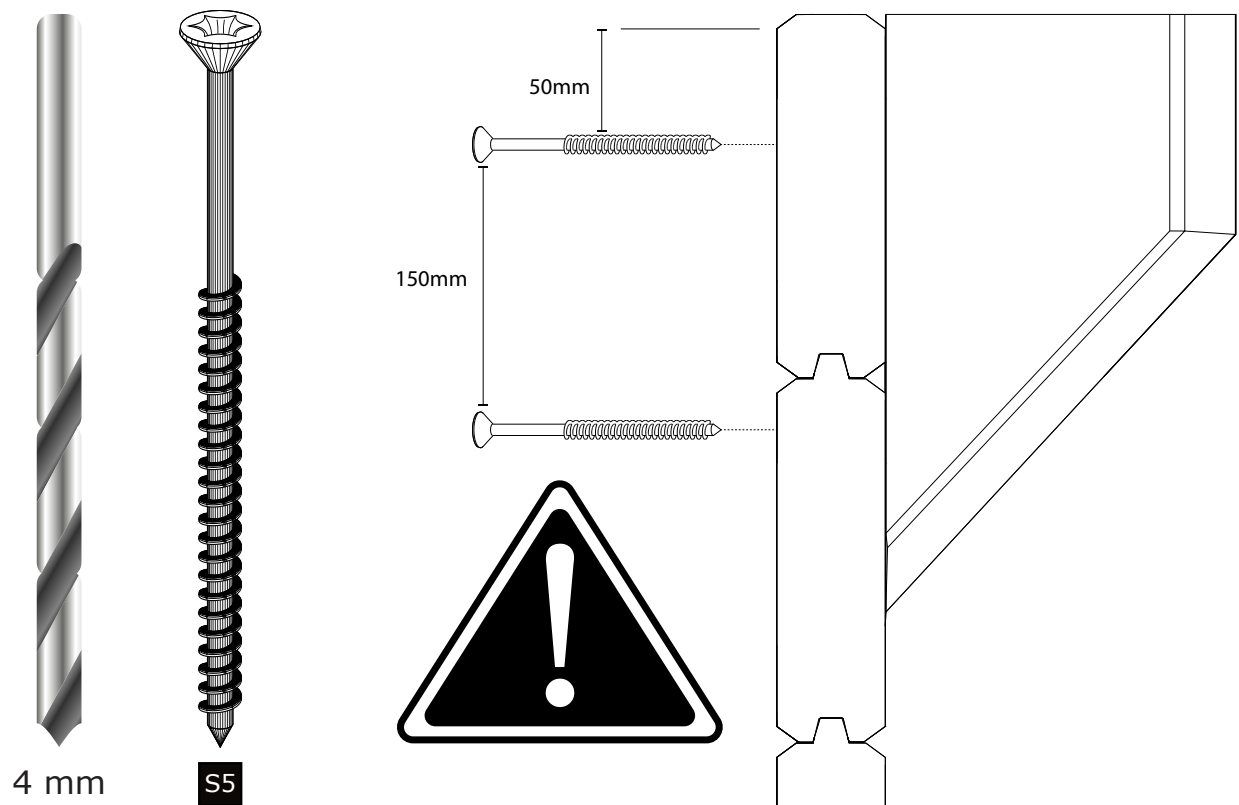
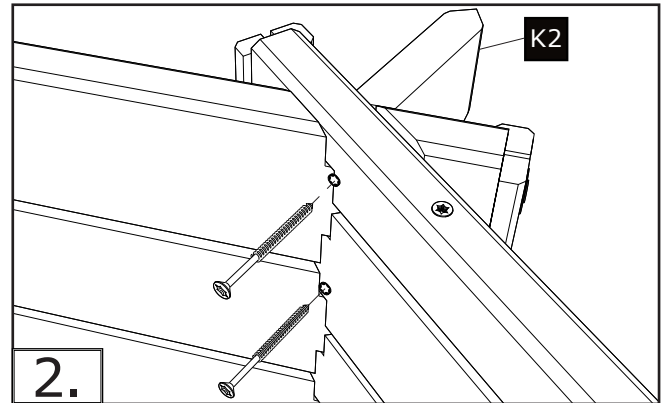
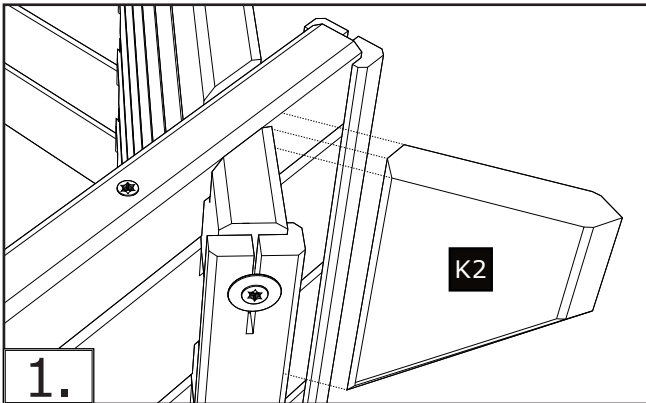

4. MONTAGE DER KONSOLEN

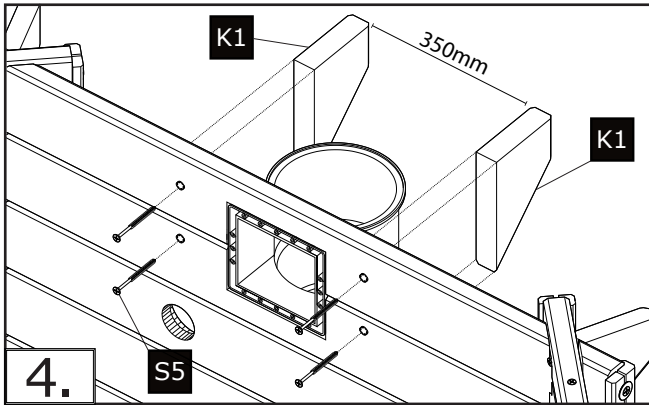

- Entscheiden Sie, an welcher Stelle Sie die Treppe montieren möchten. Sie können eine beliebige Wand, außer der mit dem Skimmer auswählen.

5.

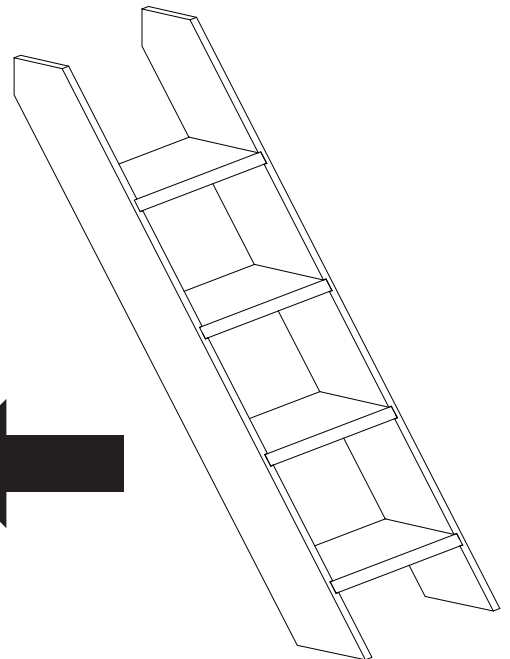
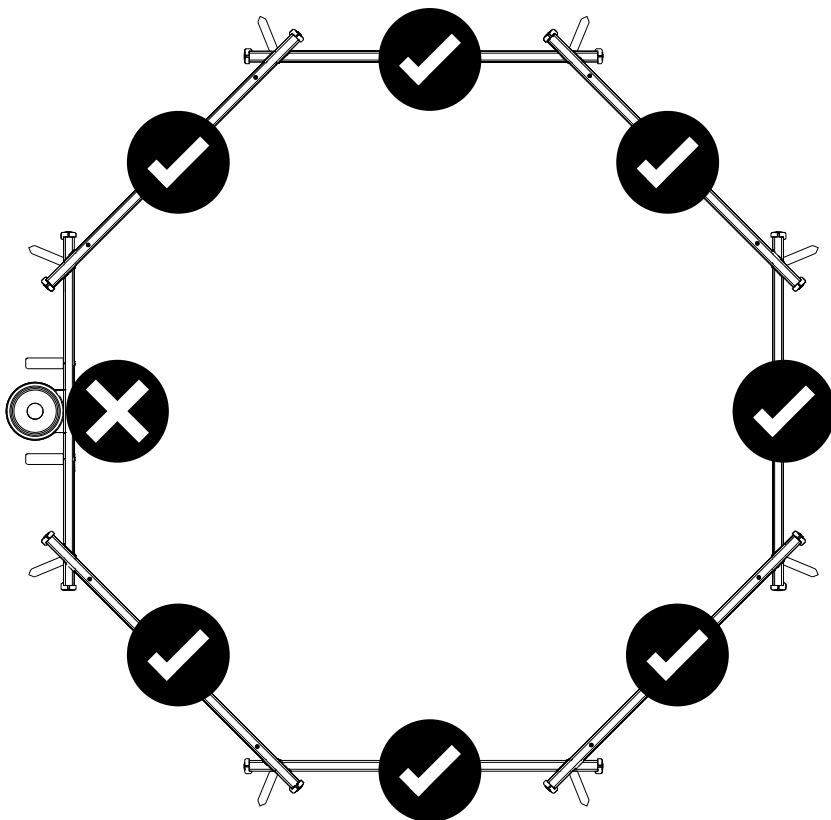

- Wenn Sie Ihre Wunschstelle ausgewählt haben, dann benutzen Sie die untenstehenden Konsolen für die Montage der Treppenseite

x4

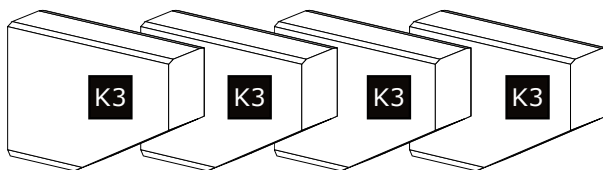

x2

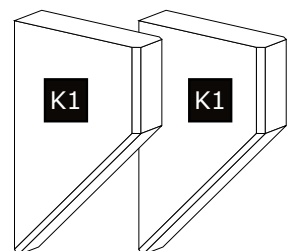

4. MONTAGE DER KONSOLEN



Bitte achten sie auf die
korrekte Anbringung der
K3 Konsolen.

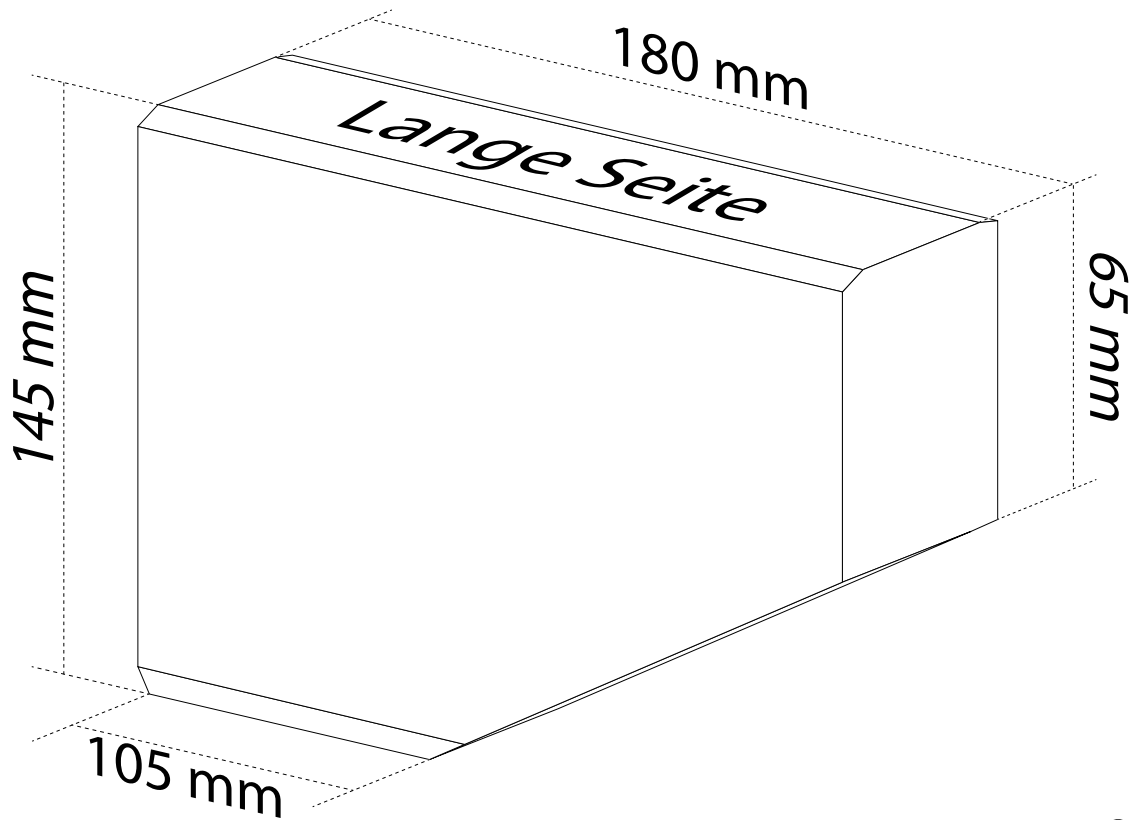

- Positionieren Sie je zwei K3 Konsolen aneinander.
- Bitte beachten Sie, dass die "lange Seite" nach oben ausgerichtet ist.

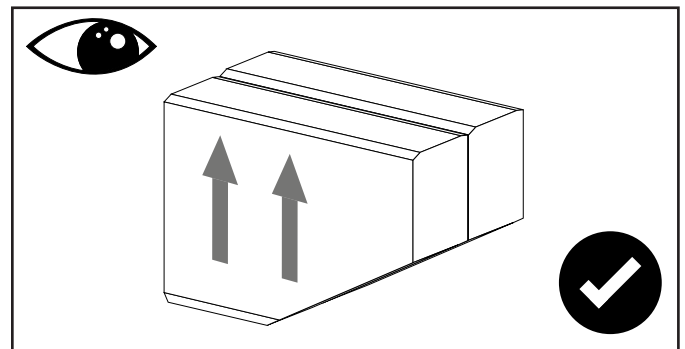
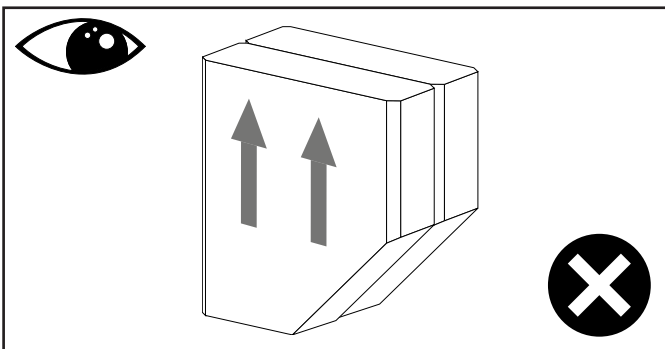

4. MONTAGE DER KONSOLEN

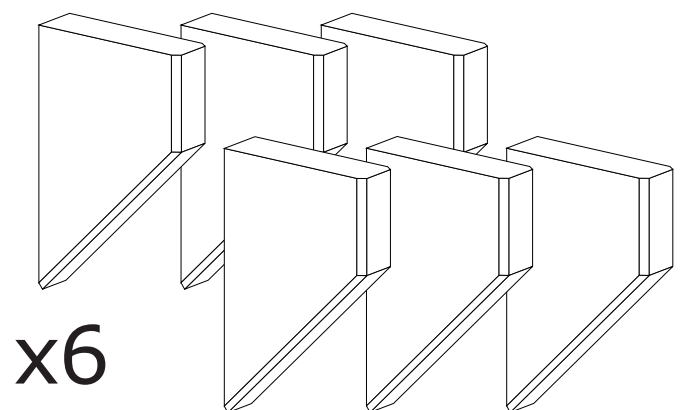
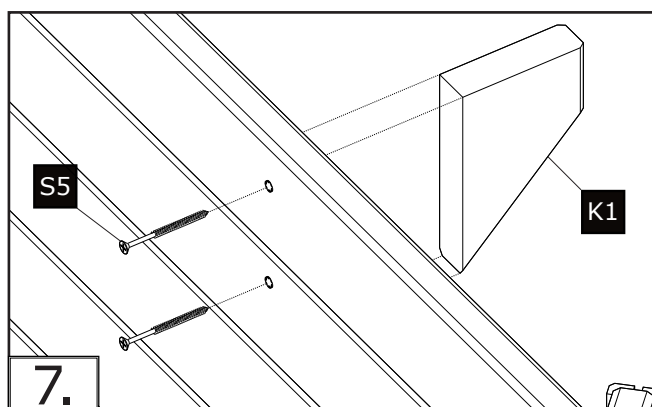
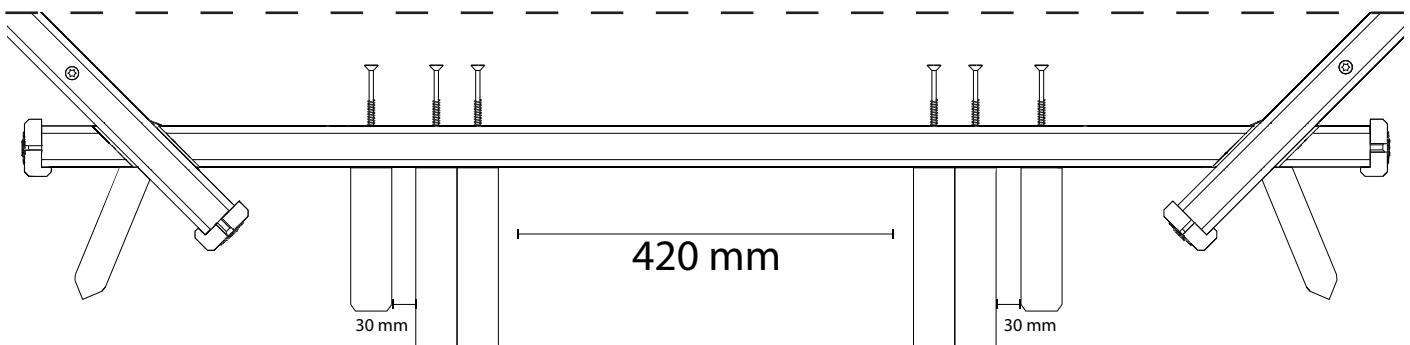
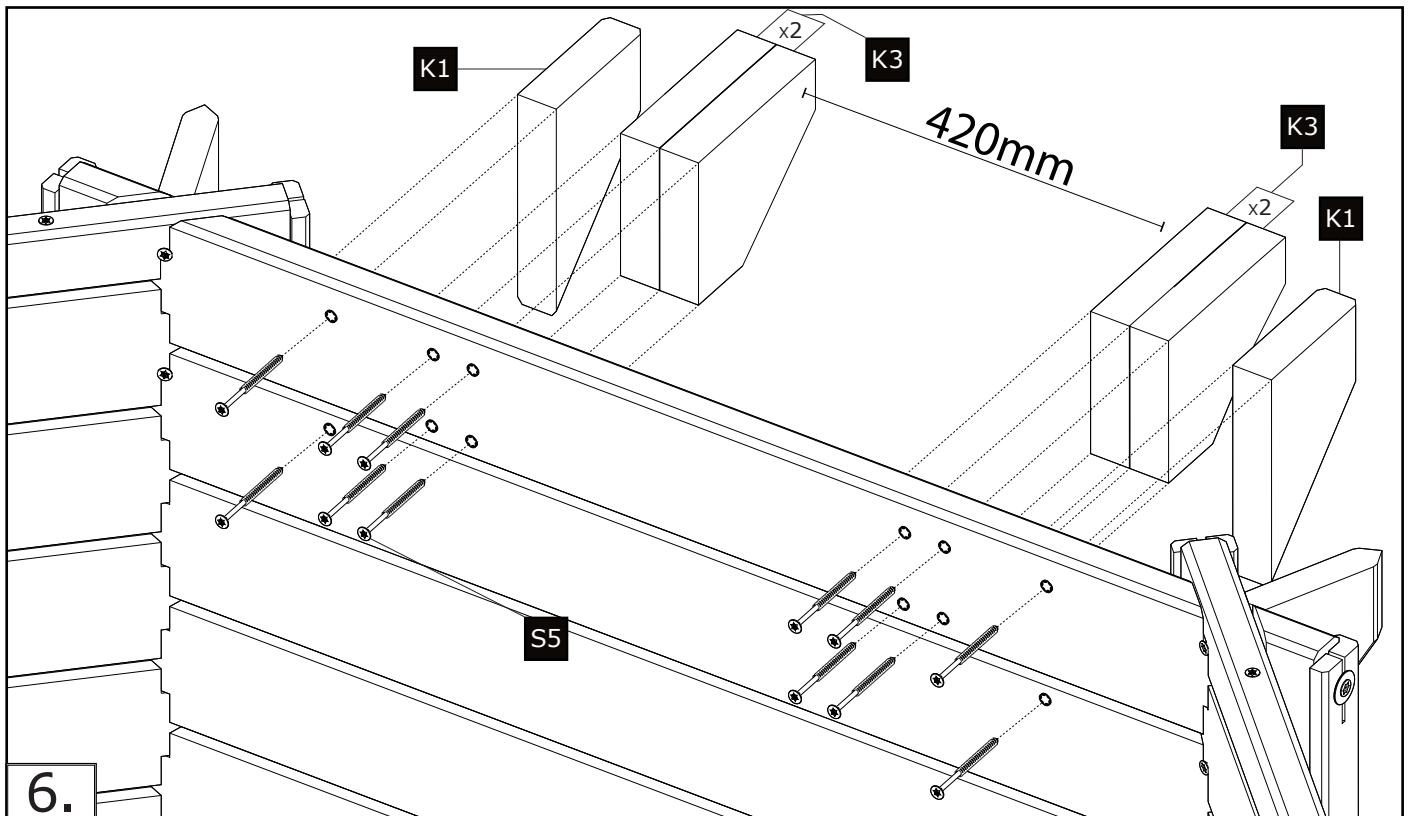

5. MONTAGE WANDVLIES - ÜBERSICHT

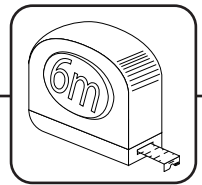
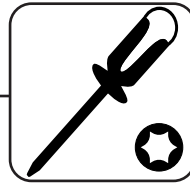
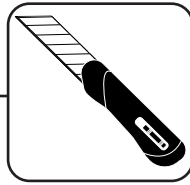
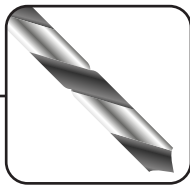
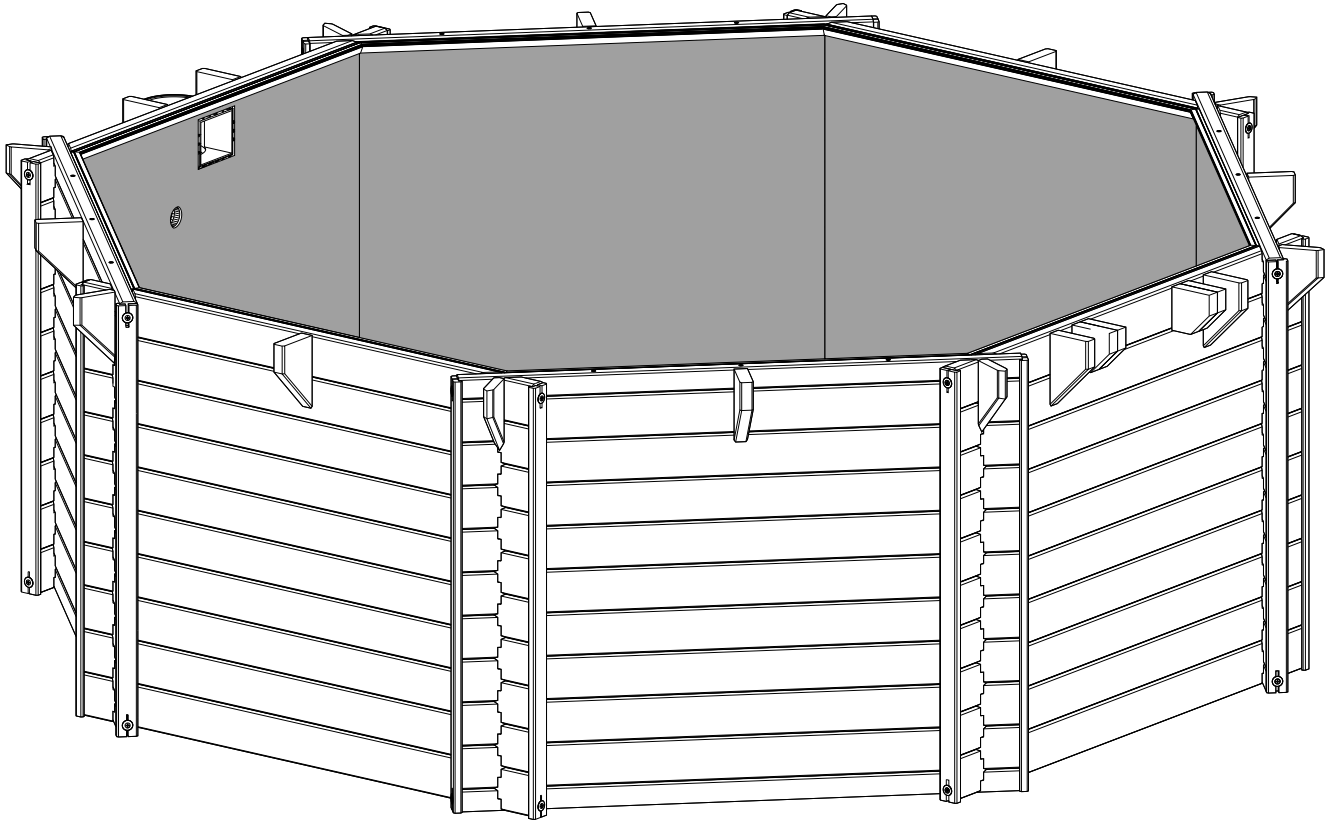

BENÖTIGTE TEILE FÜR DIESEN SCHRITT

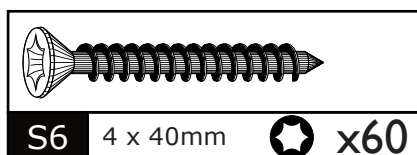
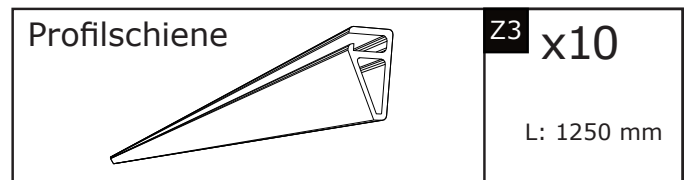
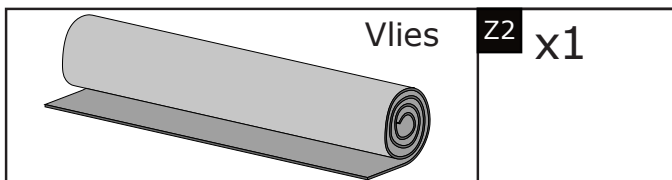

5. MONTAGE WANDVLIES

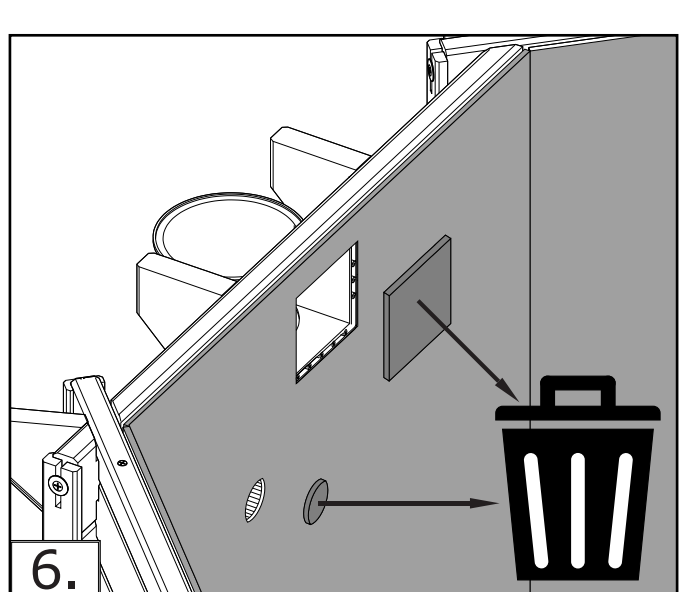
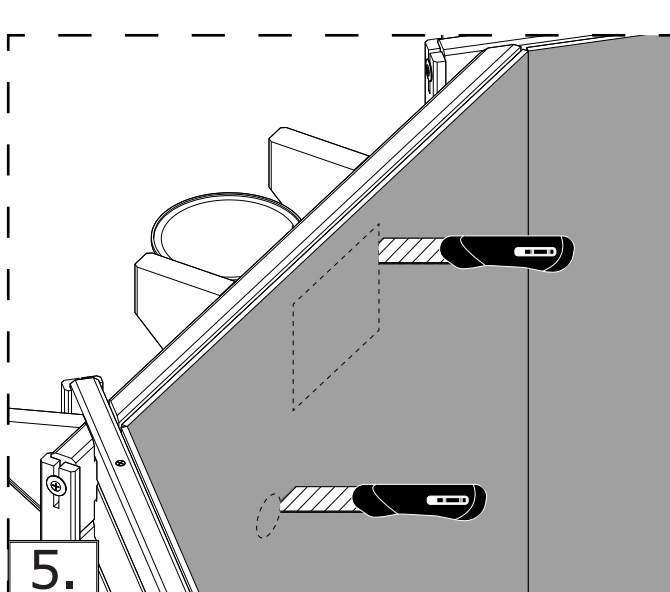
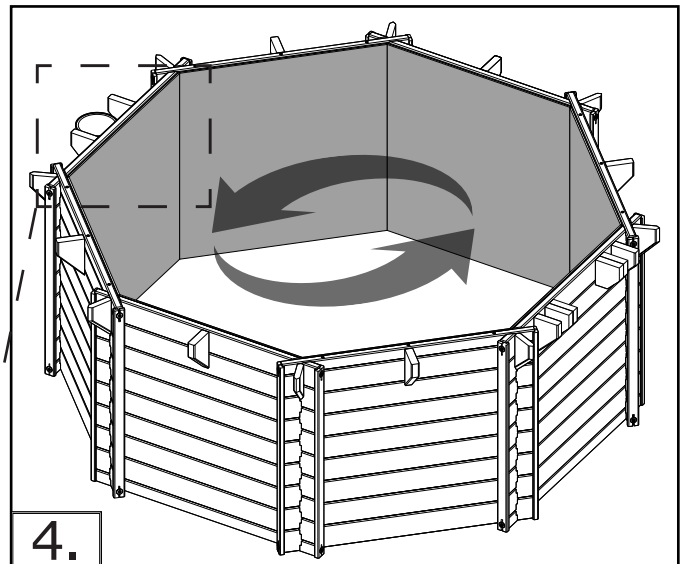
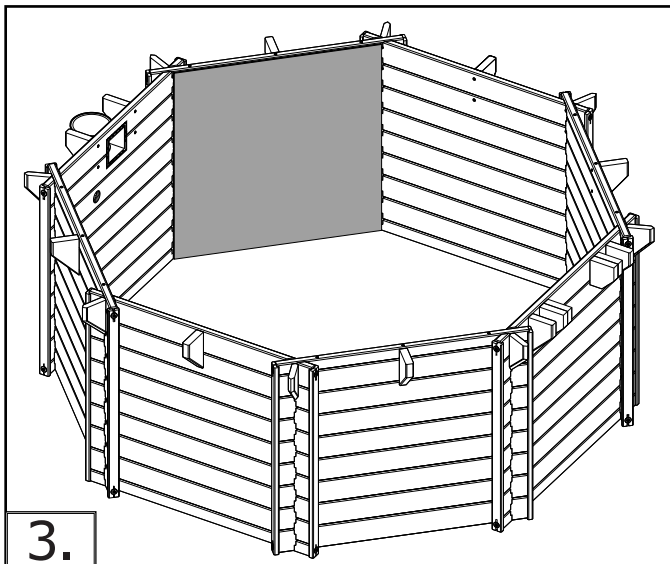
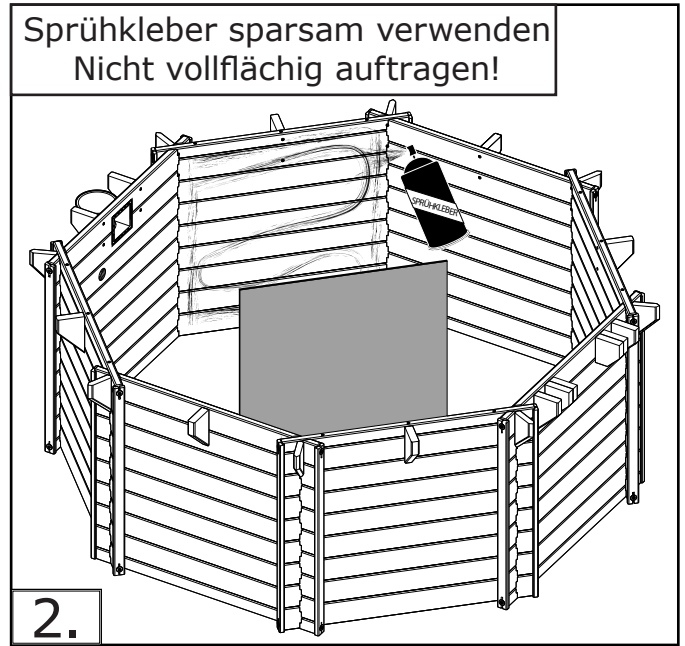
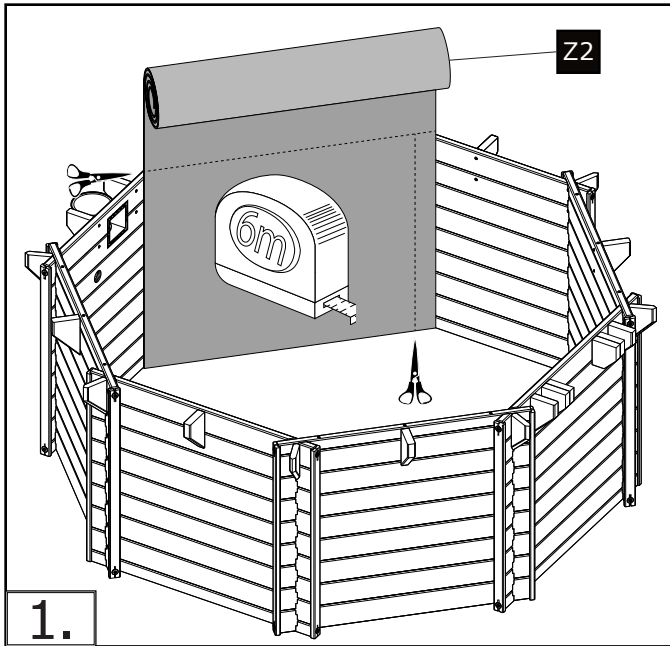

5. MONTAGE WANDVLIES

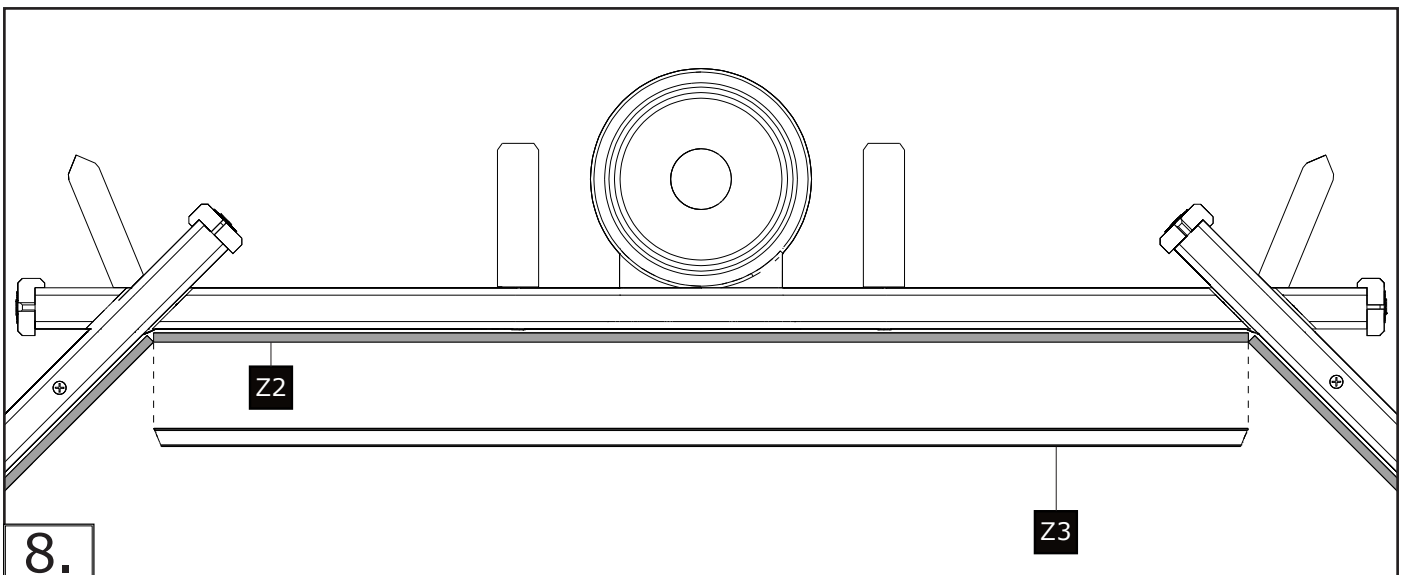
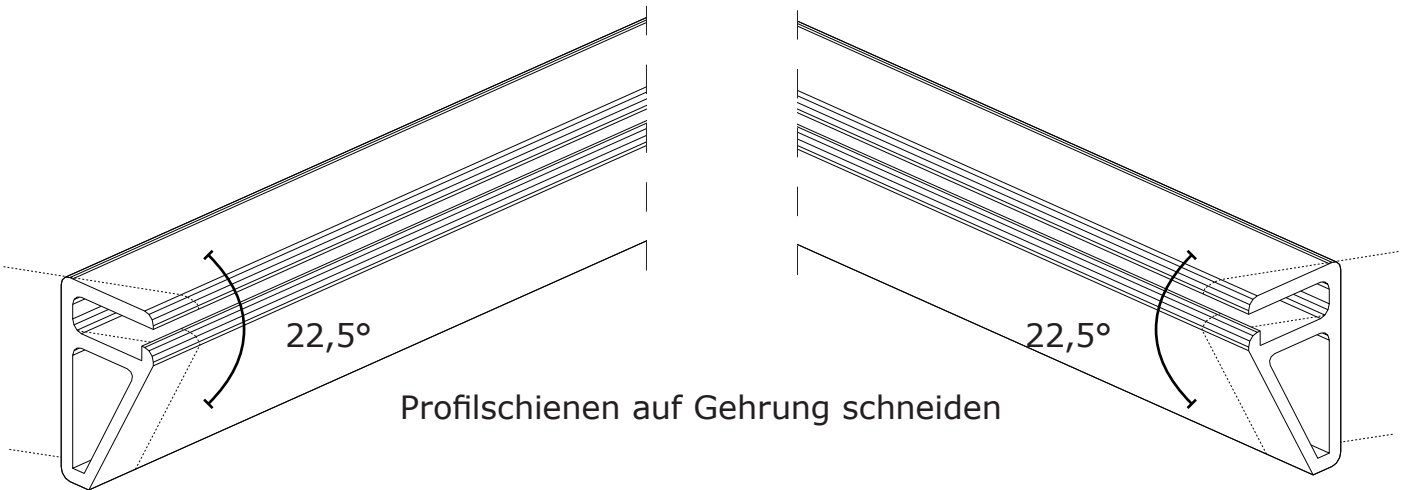
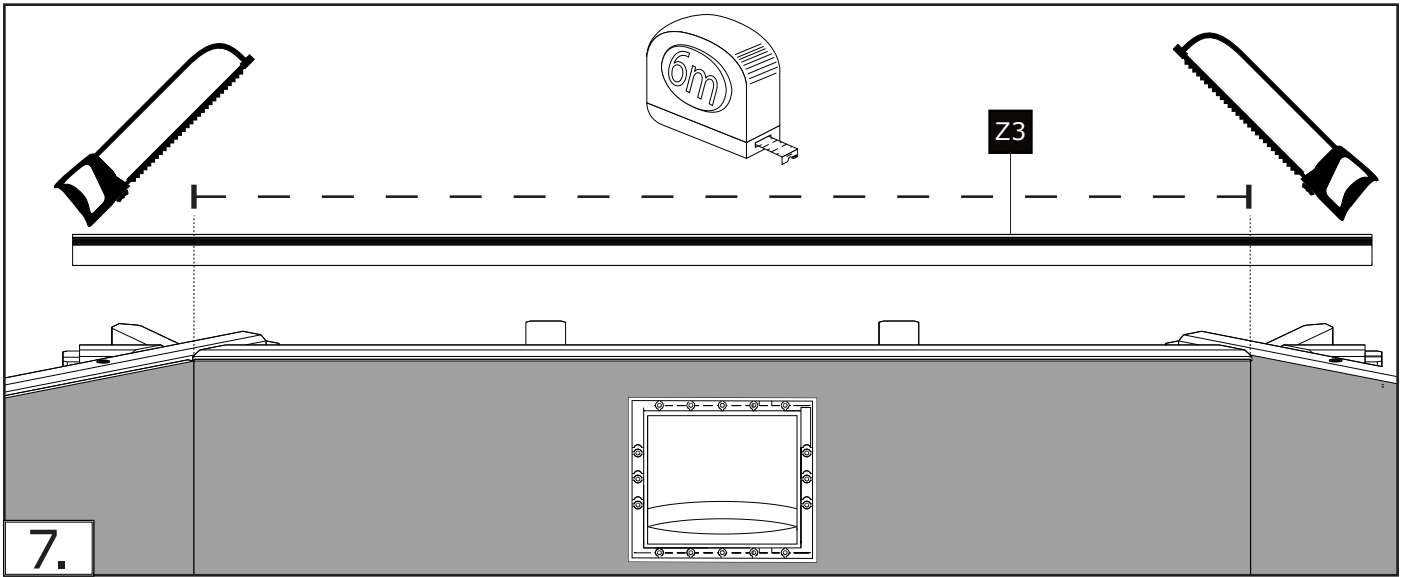

5. MONTAGE WANDVLIES

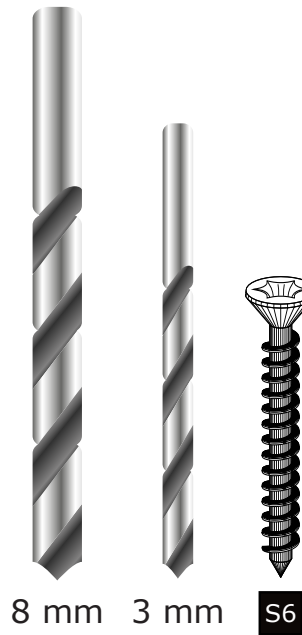
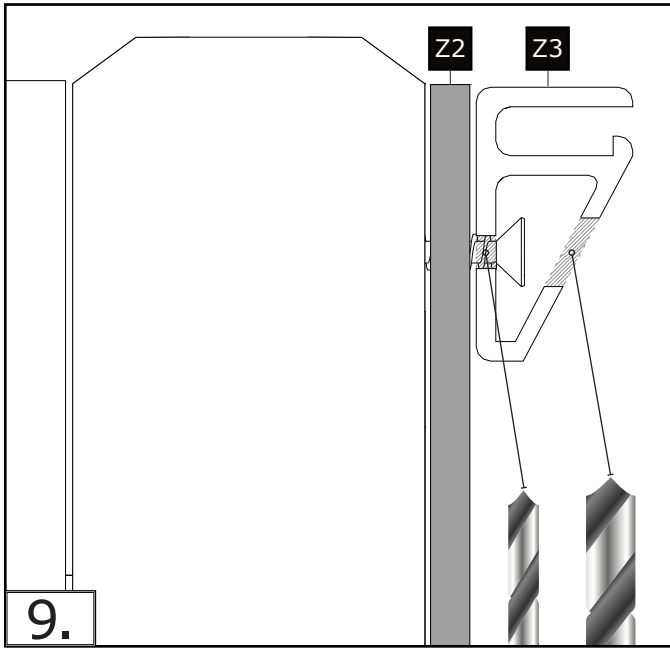

Alle Profilschienen müssen vor der Montage im Abstand von 25 cm vorgebohrt werden. Als erstes wird mit dem \varnothing 3 mm Bohrer komplett durch die Schiene gebohrt, danach mit dem \varnothing 8 mm Bohrer nur der vorderste Teil der Profilschiene.

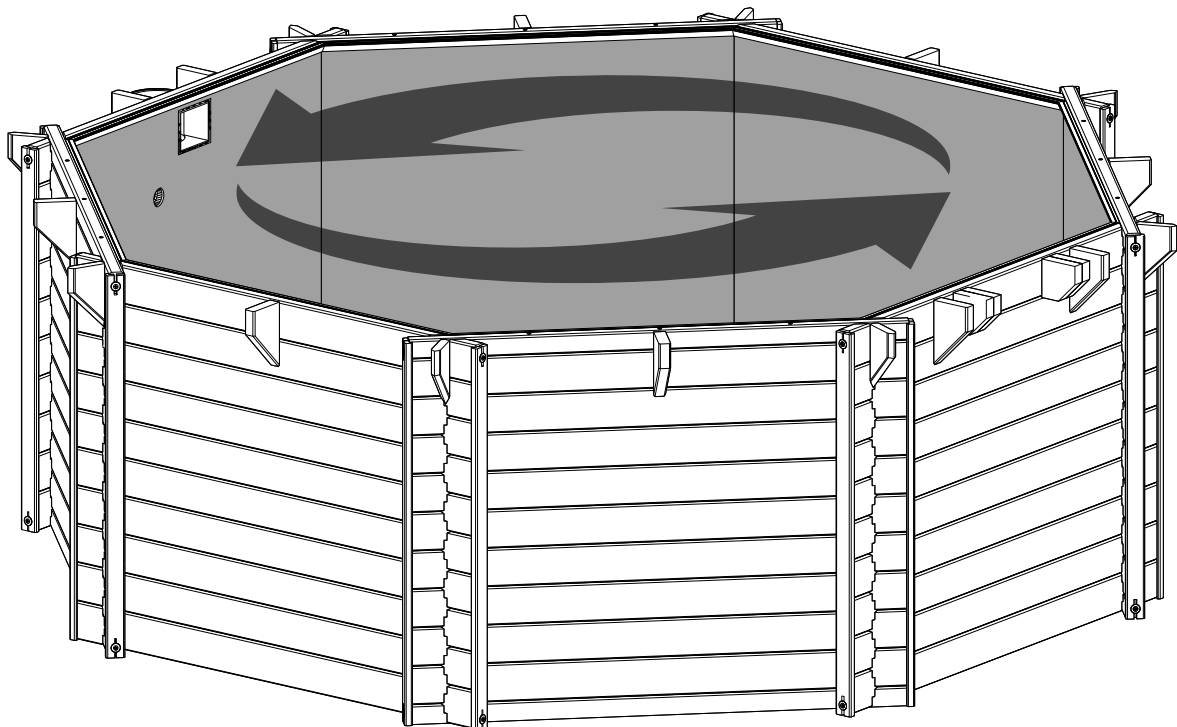
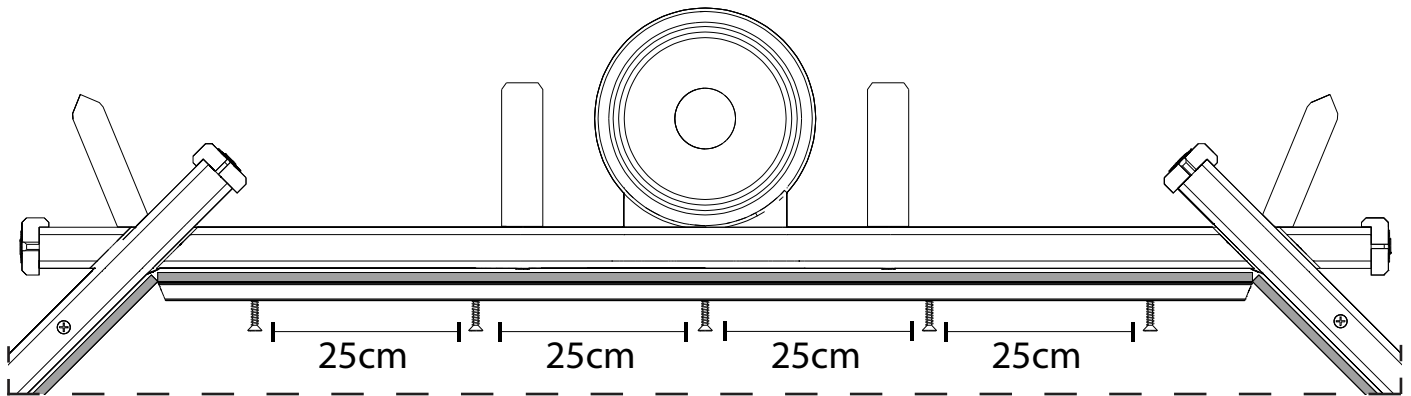

6. MONTAGE UNTERLEGVLIES - ÜBERSICHT

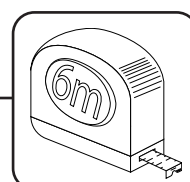
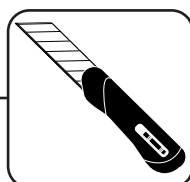
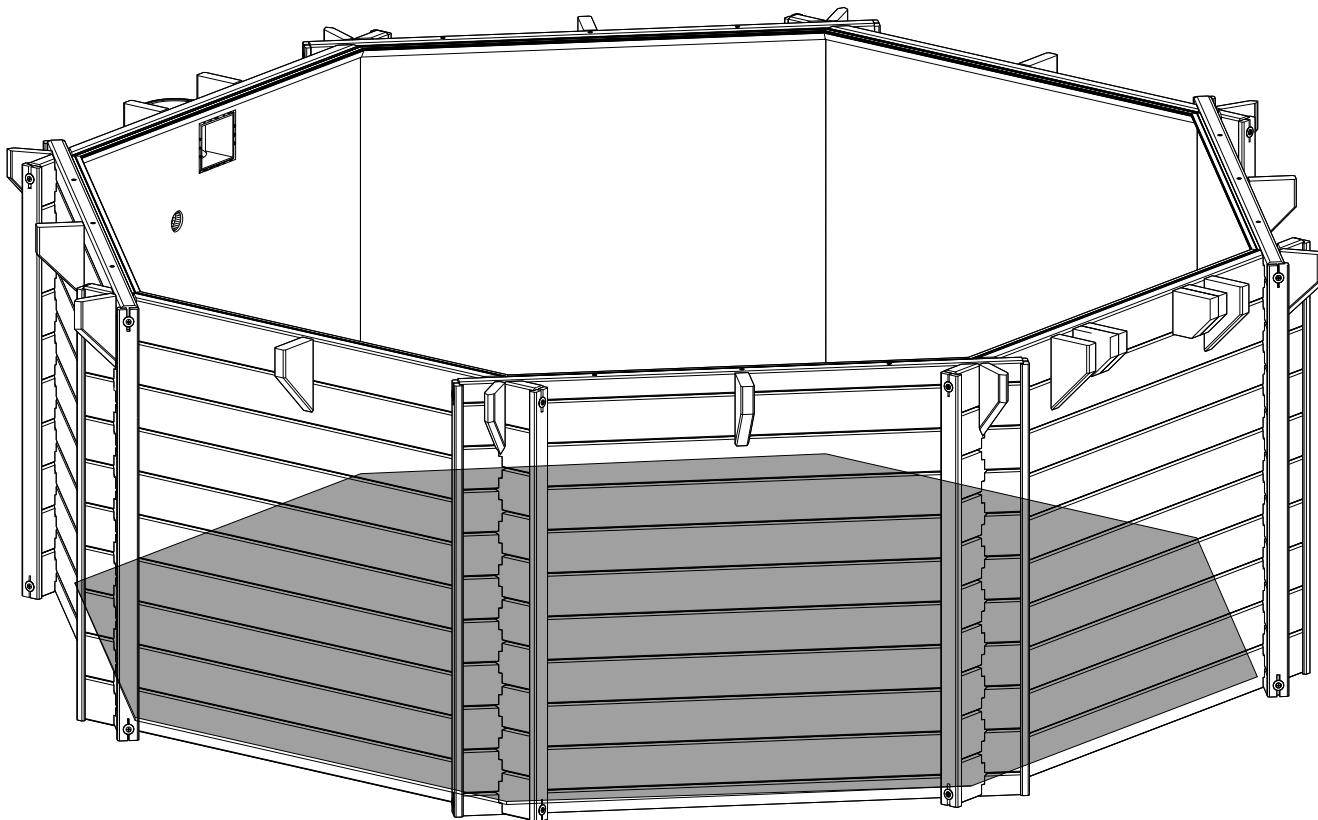

BENÖTIGTE TEILE FÜR DIESEN SCHRITT

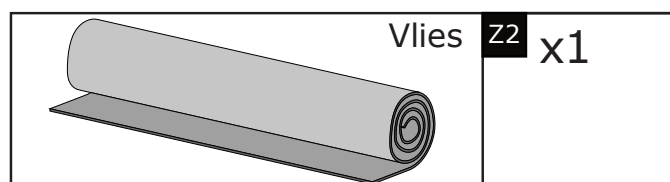

6. MONTAGE UNTERLEGVLIES

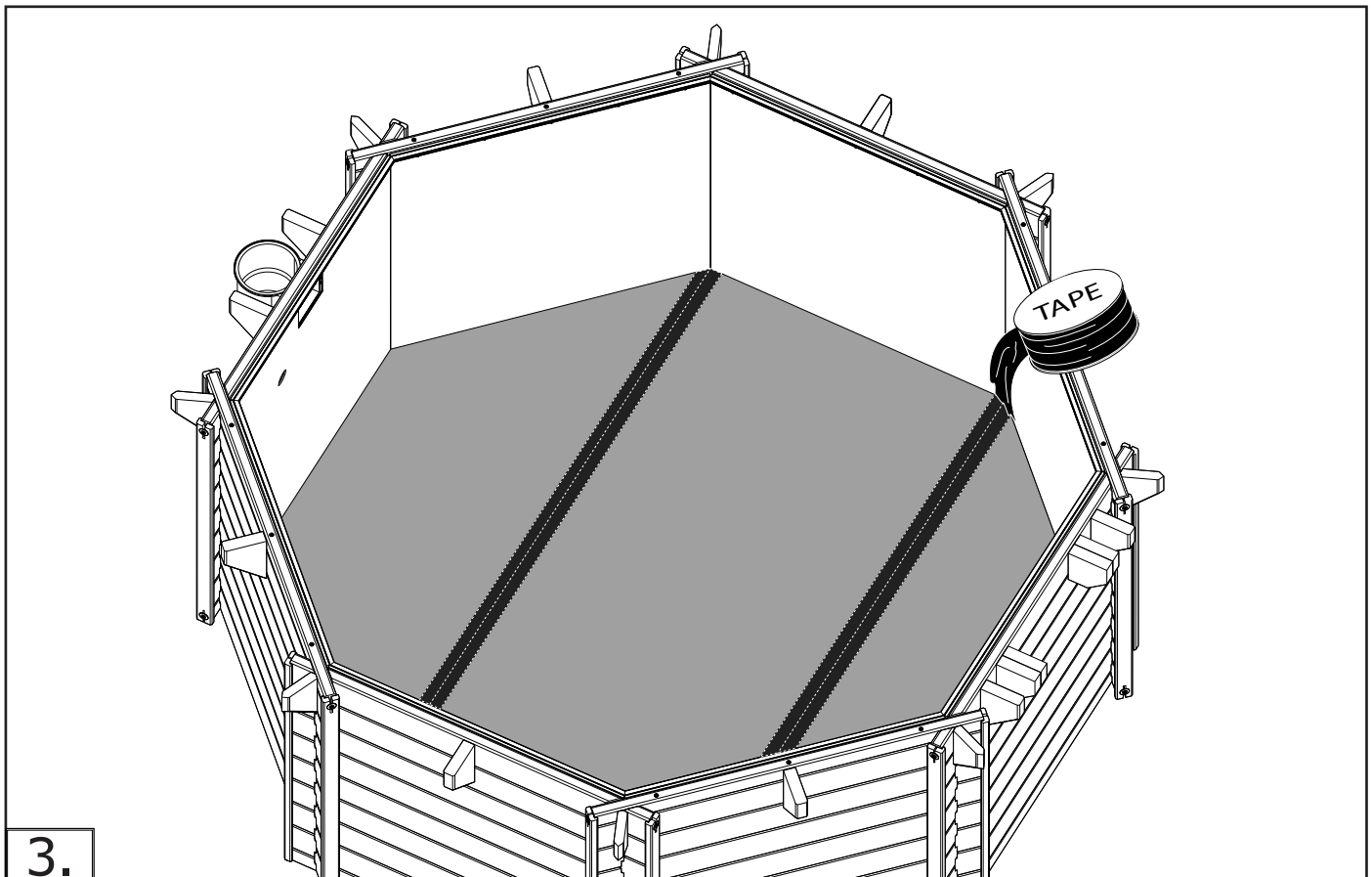
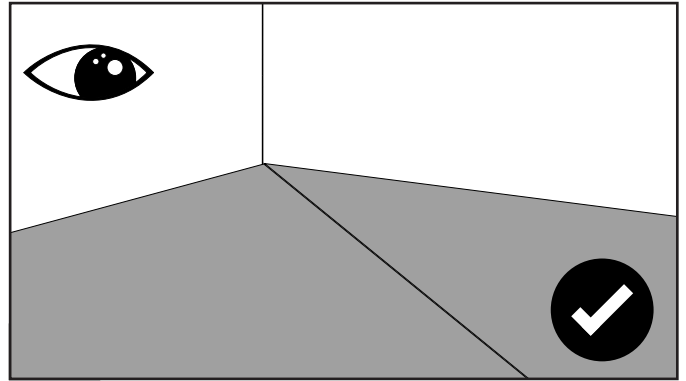
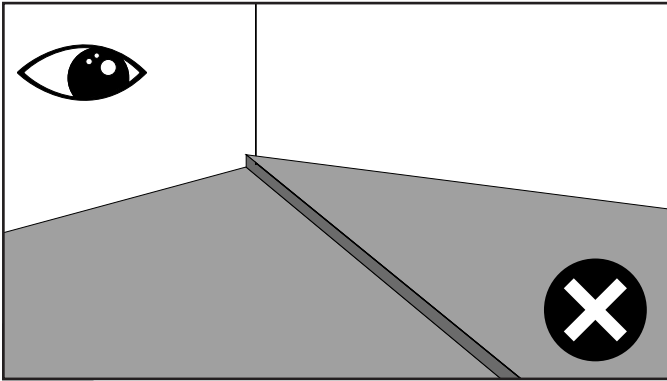
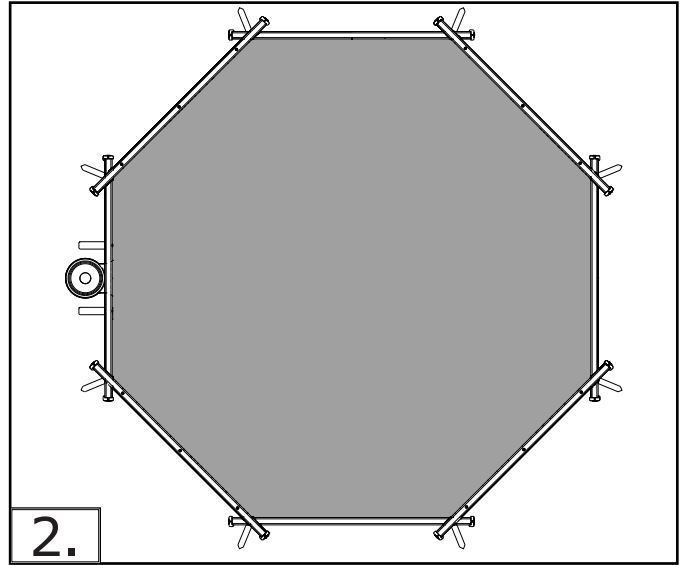
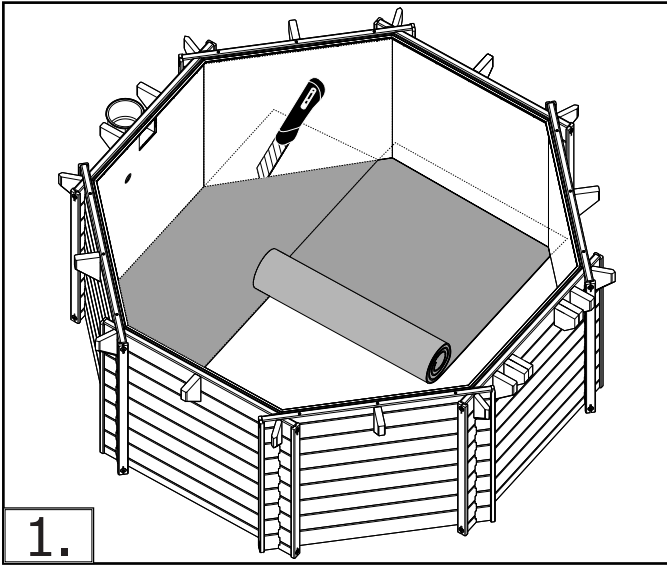

7A. EINLAUFDÜSE - VORBEREITUNG



Bitte beachten Sie, dass Sie das Düsendrundelement montieren müssen, bevor die Folie installiert wird. Ein nachträgliches einbauen der Einlaufdüse ist nicht mehr möglich. Bitte beachten Sie die Abbildungen auf dieser Seite und auf Seite 34.

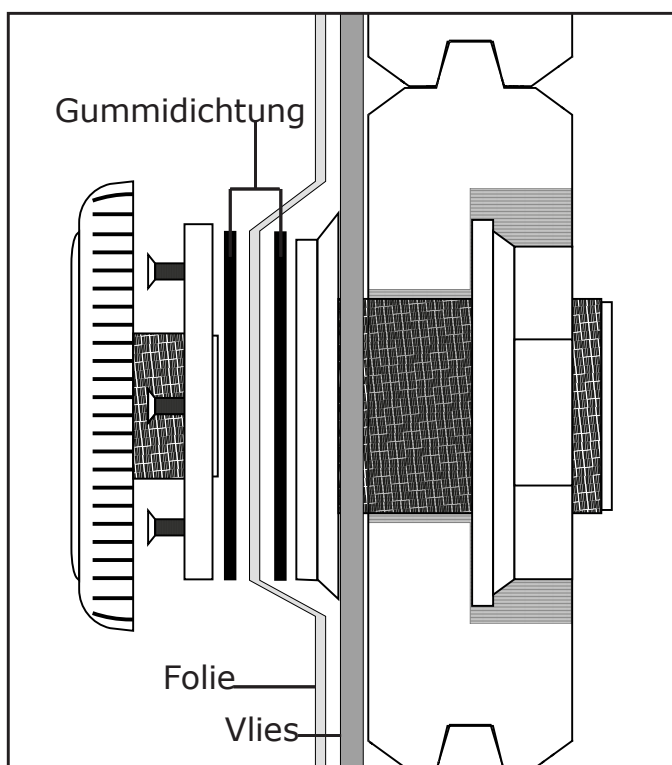
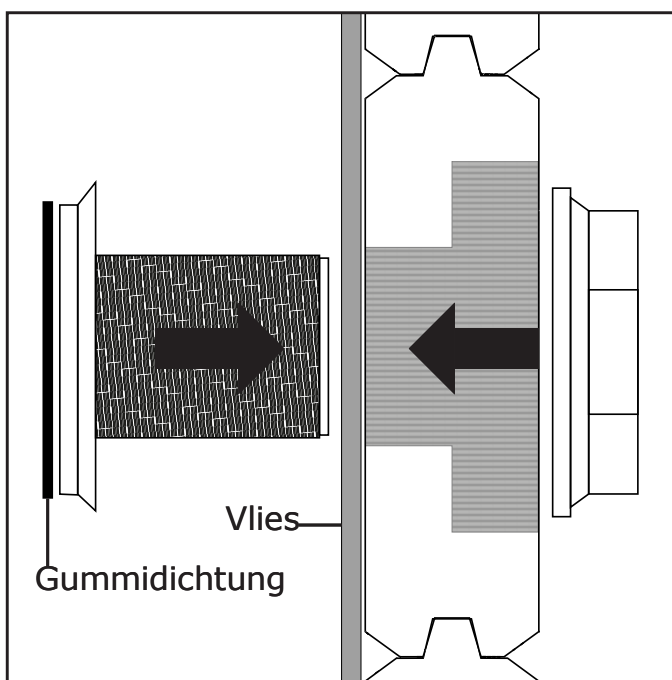

Ergebnis nach installierter Folie

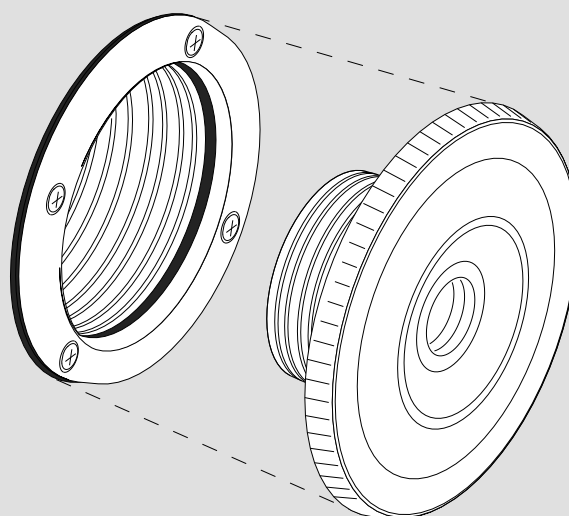

7. MONTAGE FOLIE - ÜBERSICHT

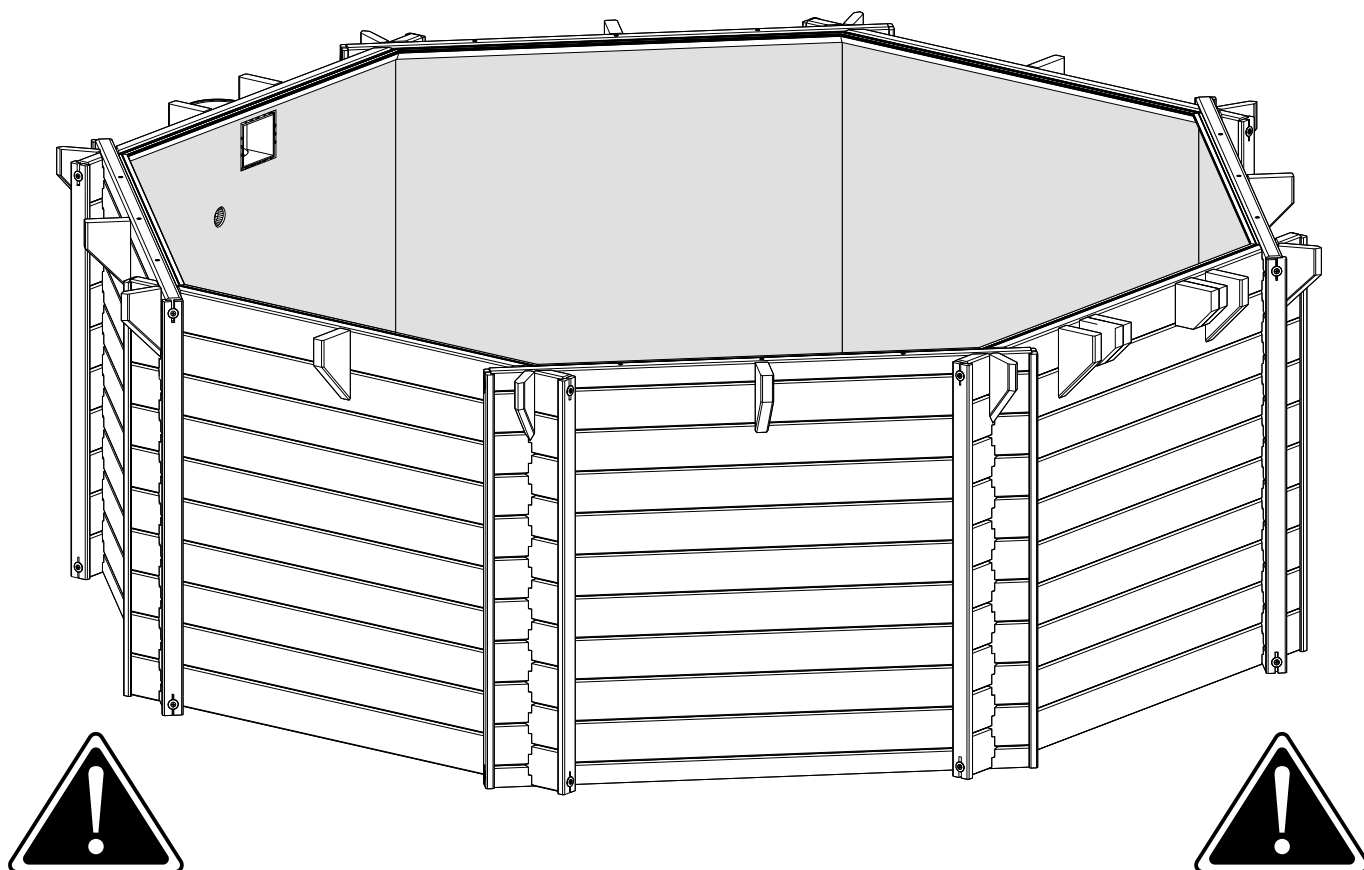

Der wichtigste Bestandteil des Beckens ist die Folienauskleidung. Schwimmbadfolie ist ein thermoplastisches Material, das sich unter Einwirkung von Wärme ausdehnt bzw. bei Kälte zusammenzieht.

Die Auskleidung soll bei Temperaturen zwischen +18°C und +25°C eingebaut werden, da bei diesen Temperaturen die Folie am einfachsten zu handhaben ist. Bei höheren Temperaturen besteht Gefahr, die Folie zu überdehnen. Bei zu niedriger Temperatur ist die Folie hart, unelastisch und fertigungsbedingte Legefalten lassen sich am Beckenboden schlecht ausgleichen.

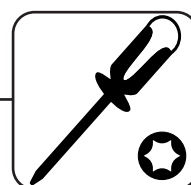
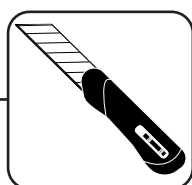
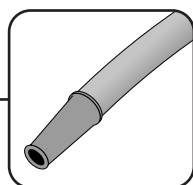

BENÖTIGTE TEILE FÜR DIESEN SCHRITT

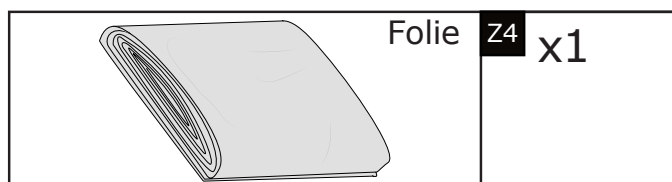

7. MONTAGE FOLIE

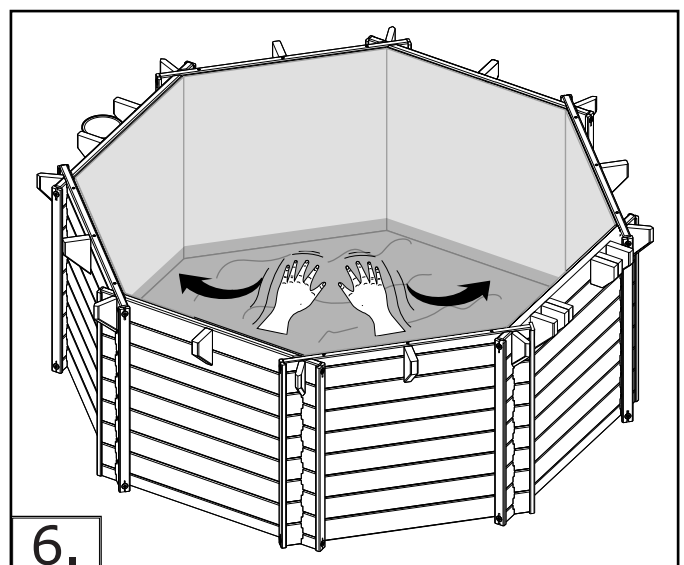
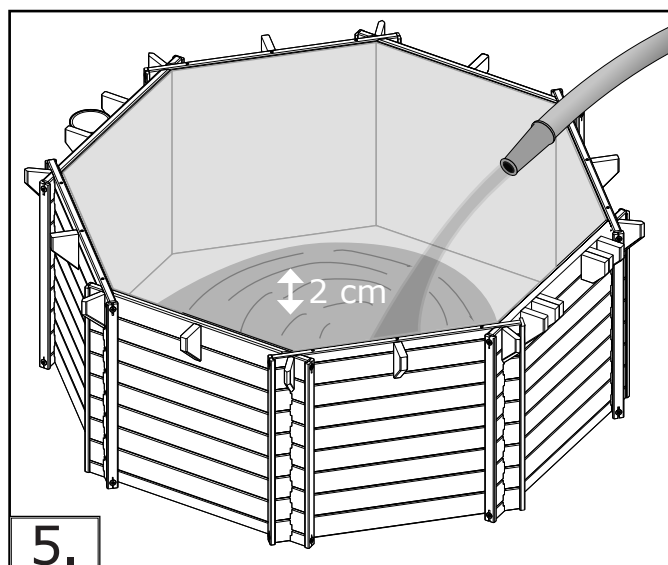
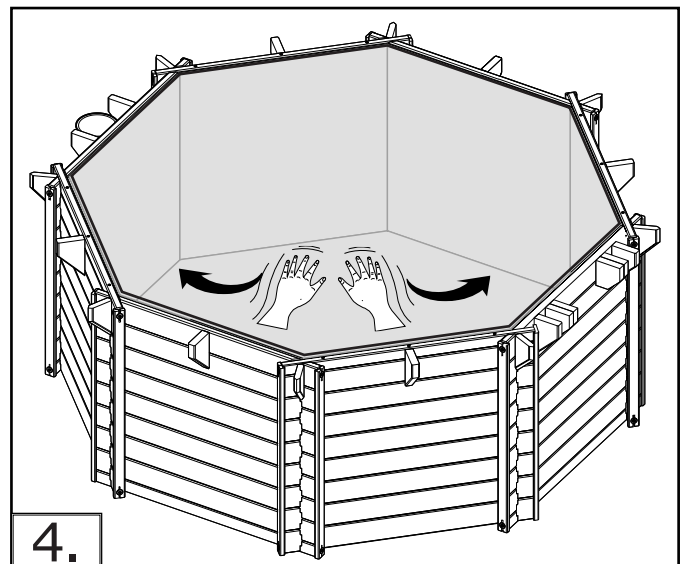
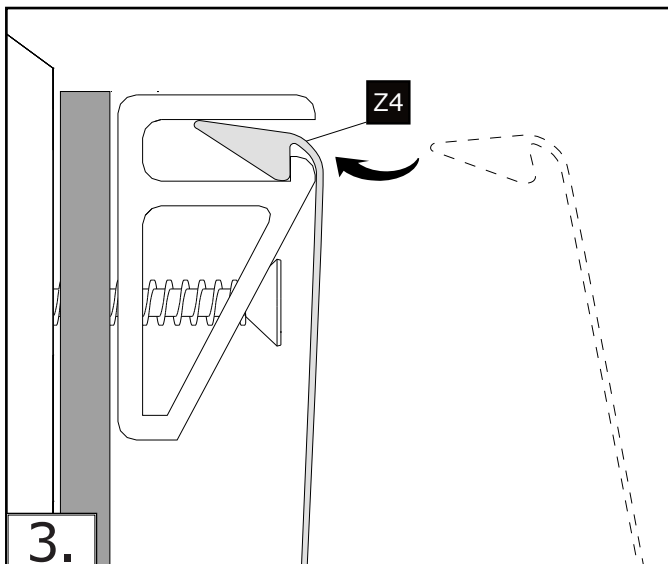
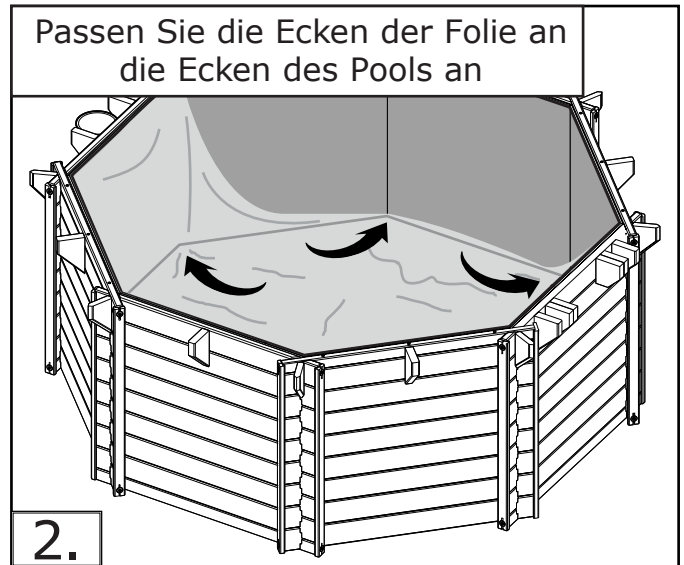
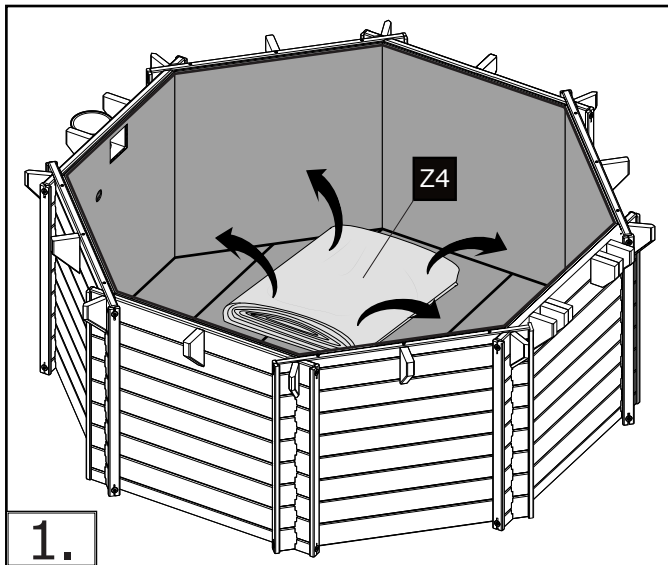

7A. EINLAUFDÜSE - FERTIGSTELLUNG

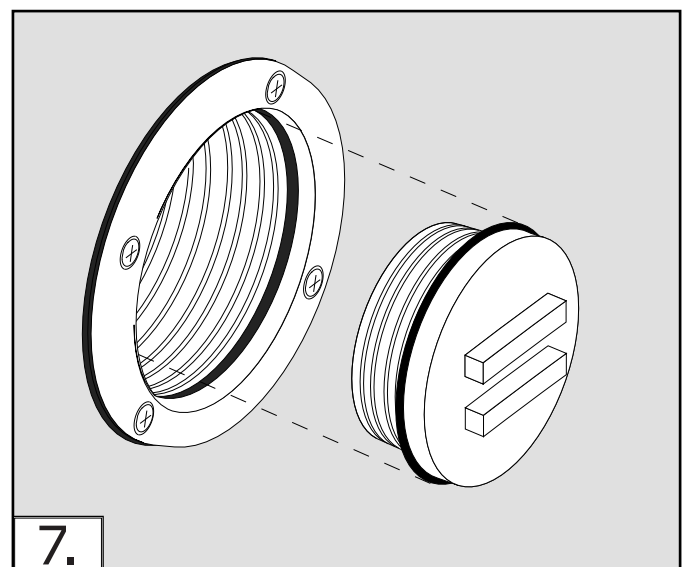
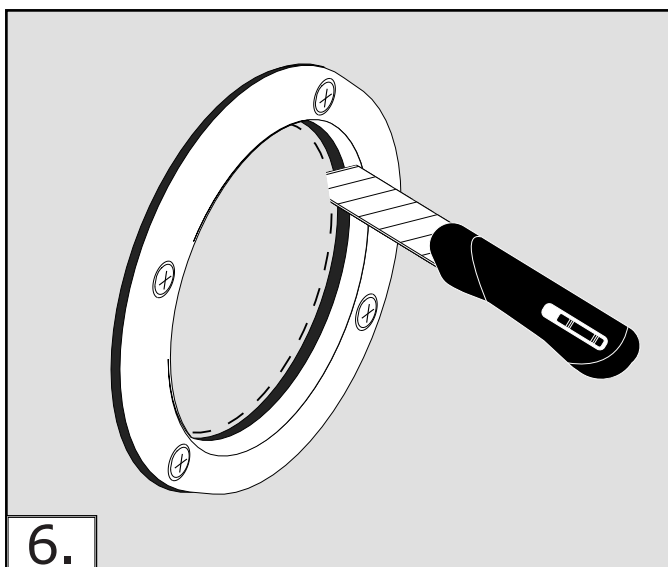
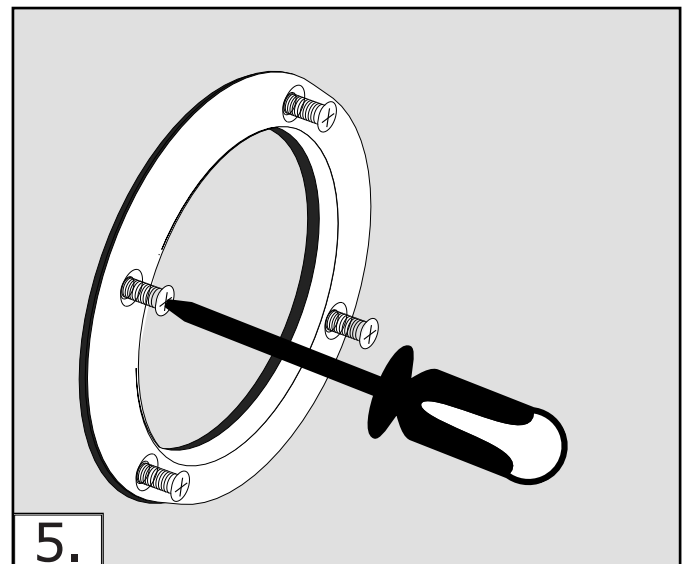
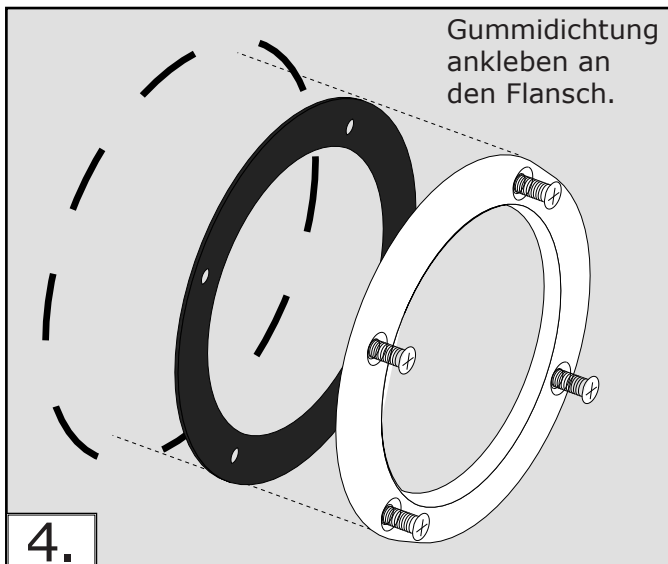
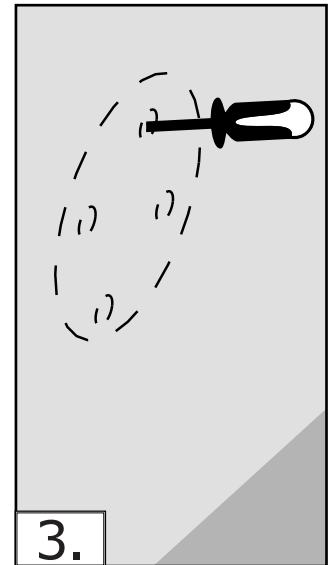
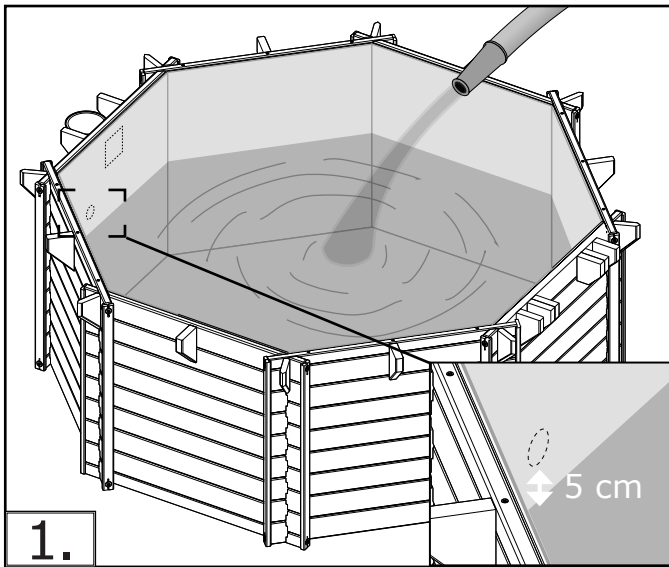

8. MONTAGE SKIMMER FERTIGSTELLUNG - ÜBERSICHT

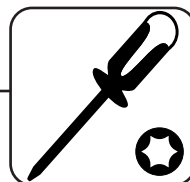
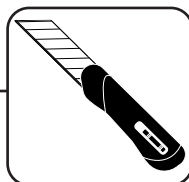
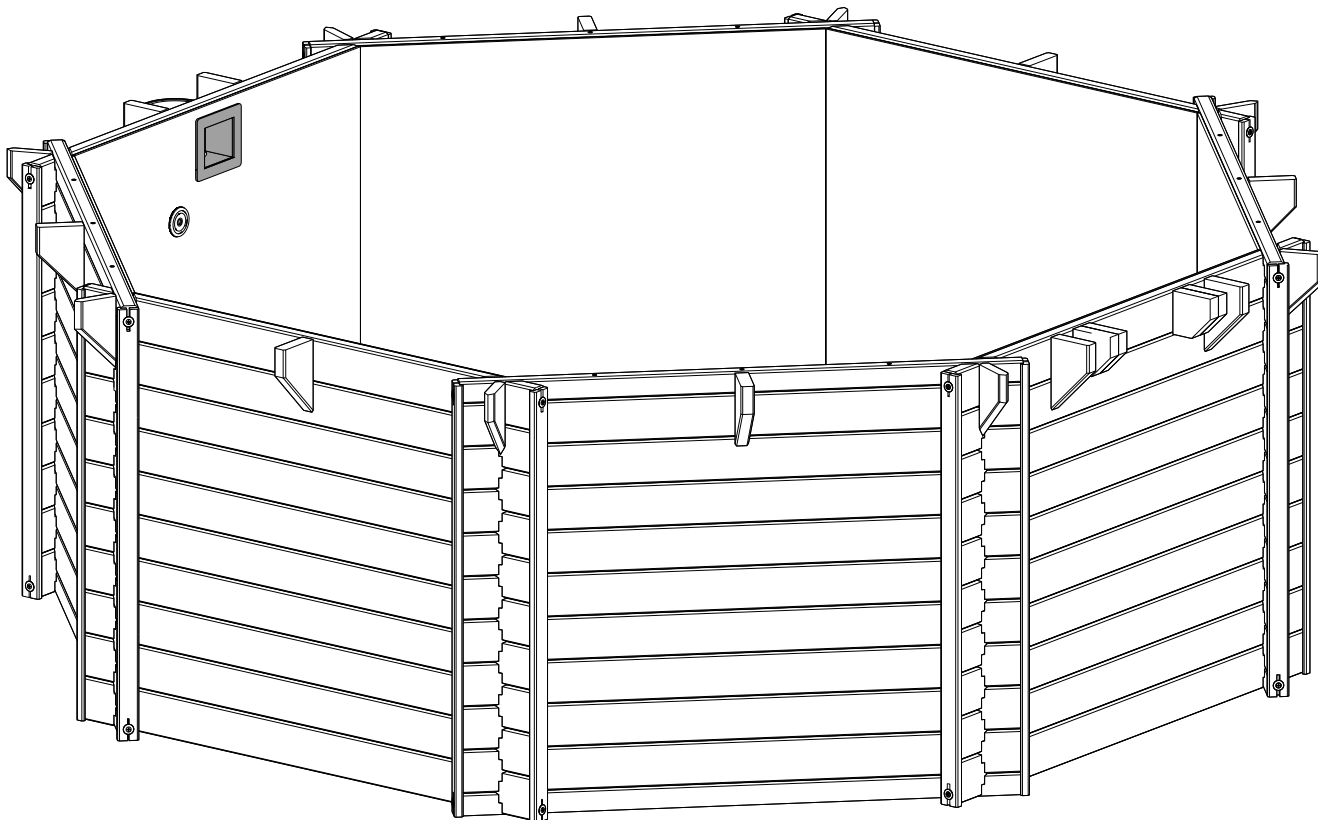

BENÖTIGTE TEILE FÜR DIESEN SCHRITT

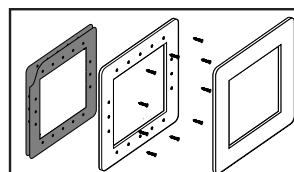

Skimmer
set

Z1 x1

8. SKIMMER-FERTIGSTELLUNG

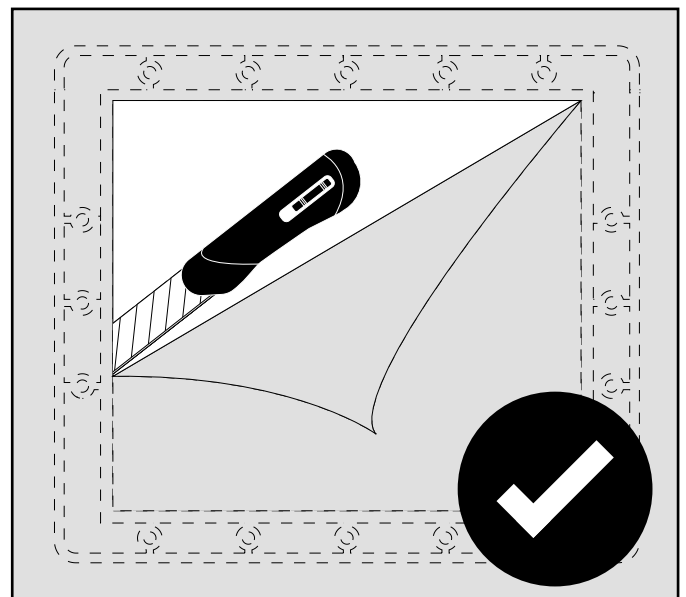
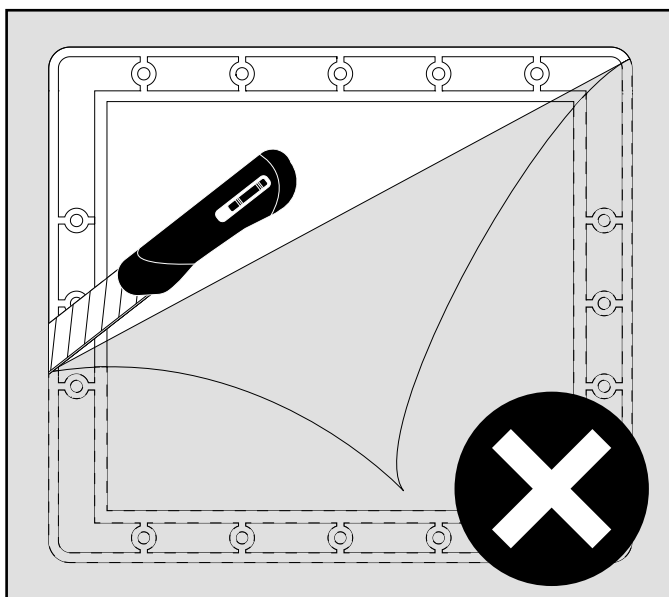
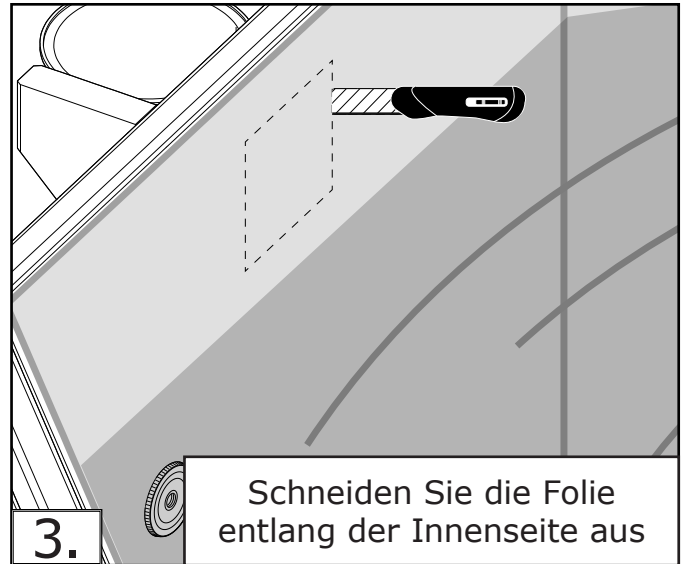
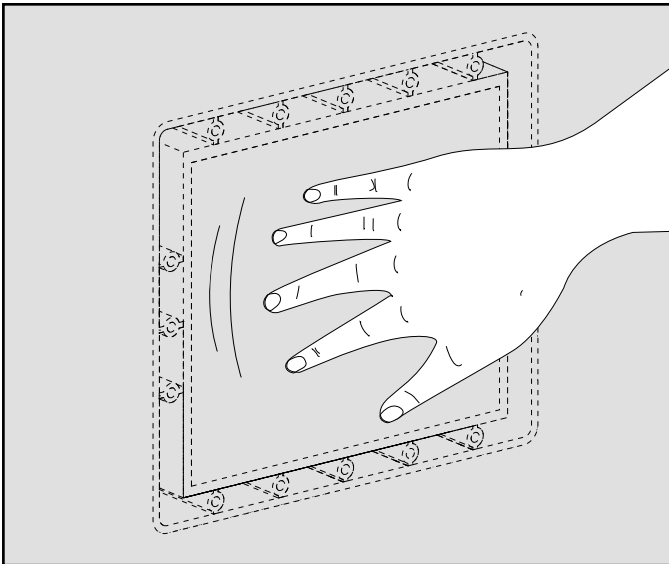
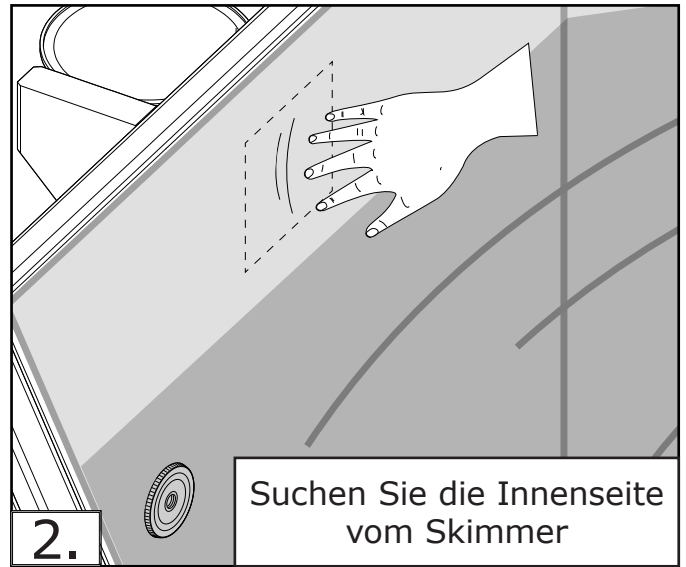
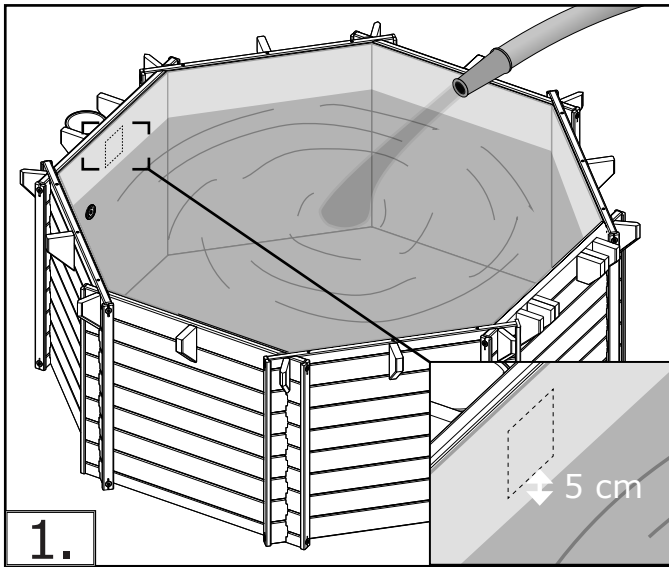

8. SKIMMER-FERTIGSTELLUNG

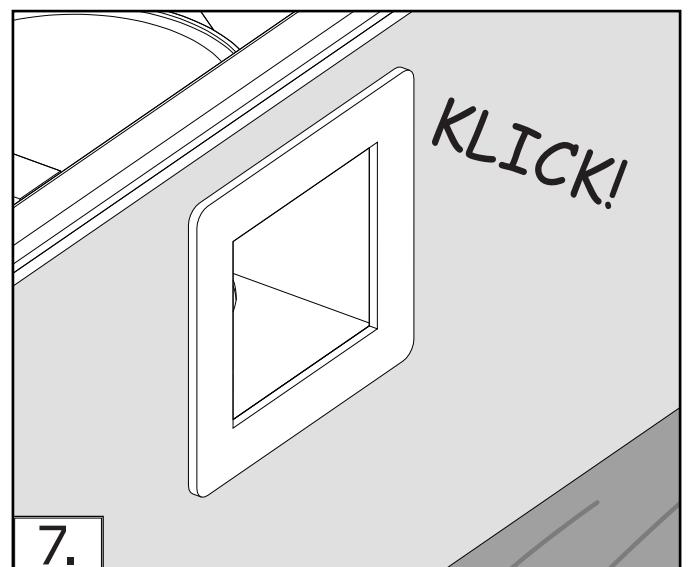
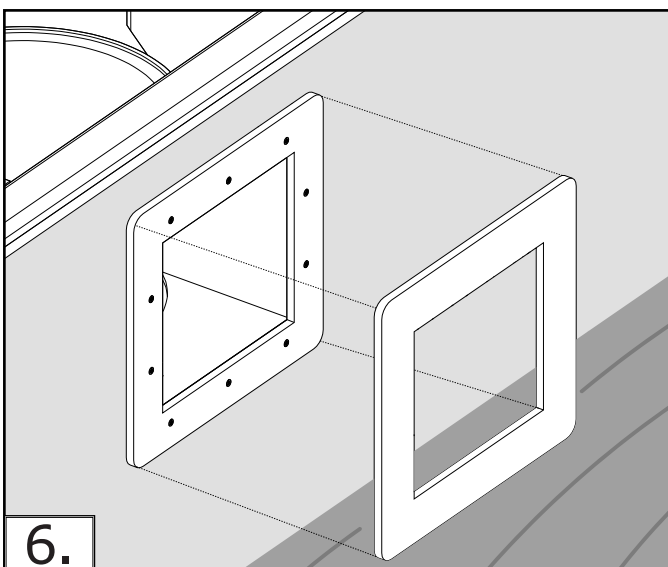
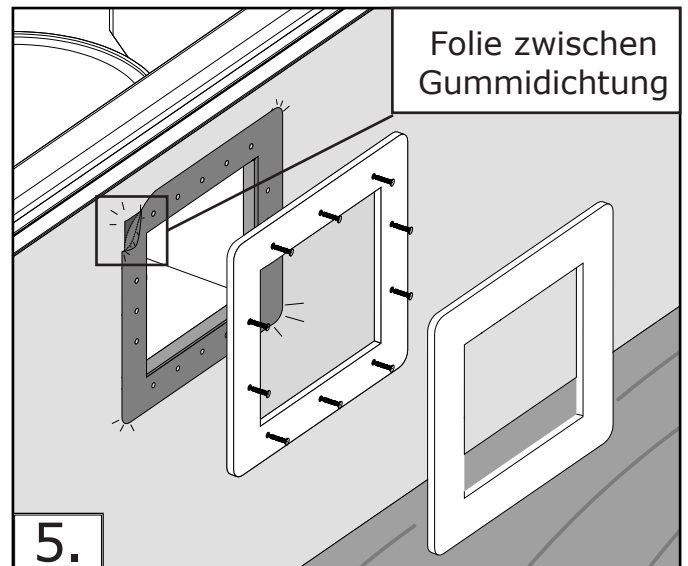
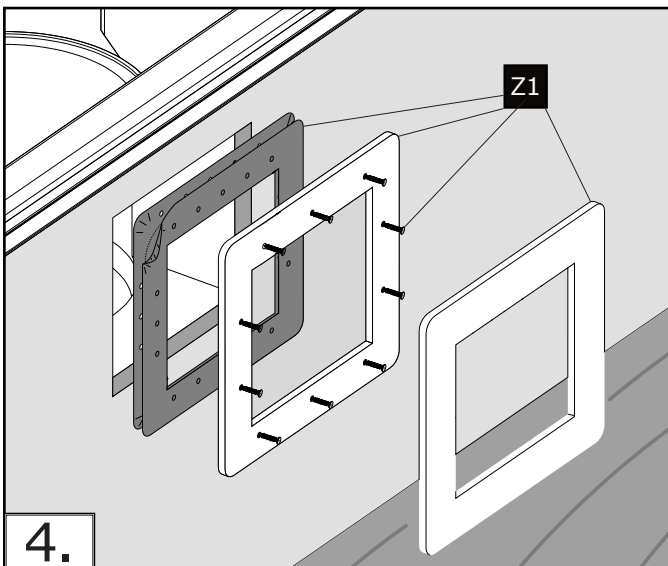
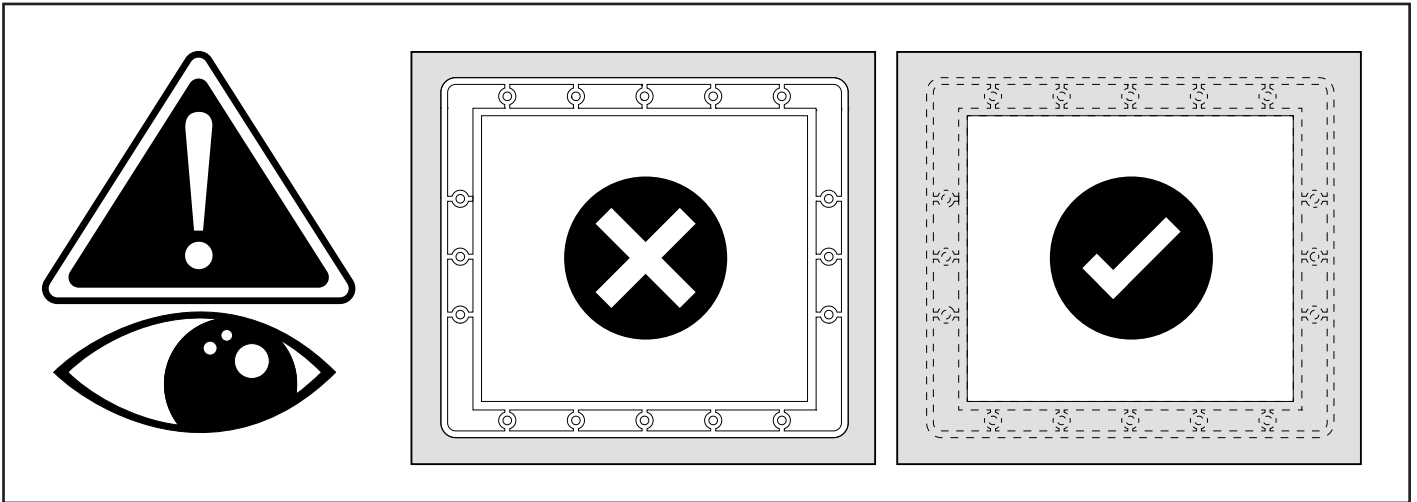

9. MONTAGE DER TREPPE - ÜBERSICHT

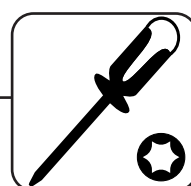
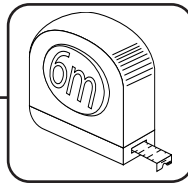
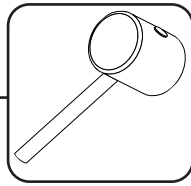
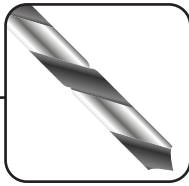
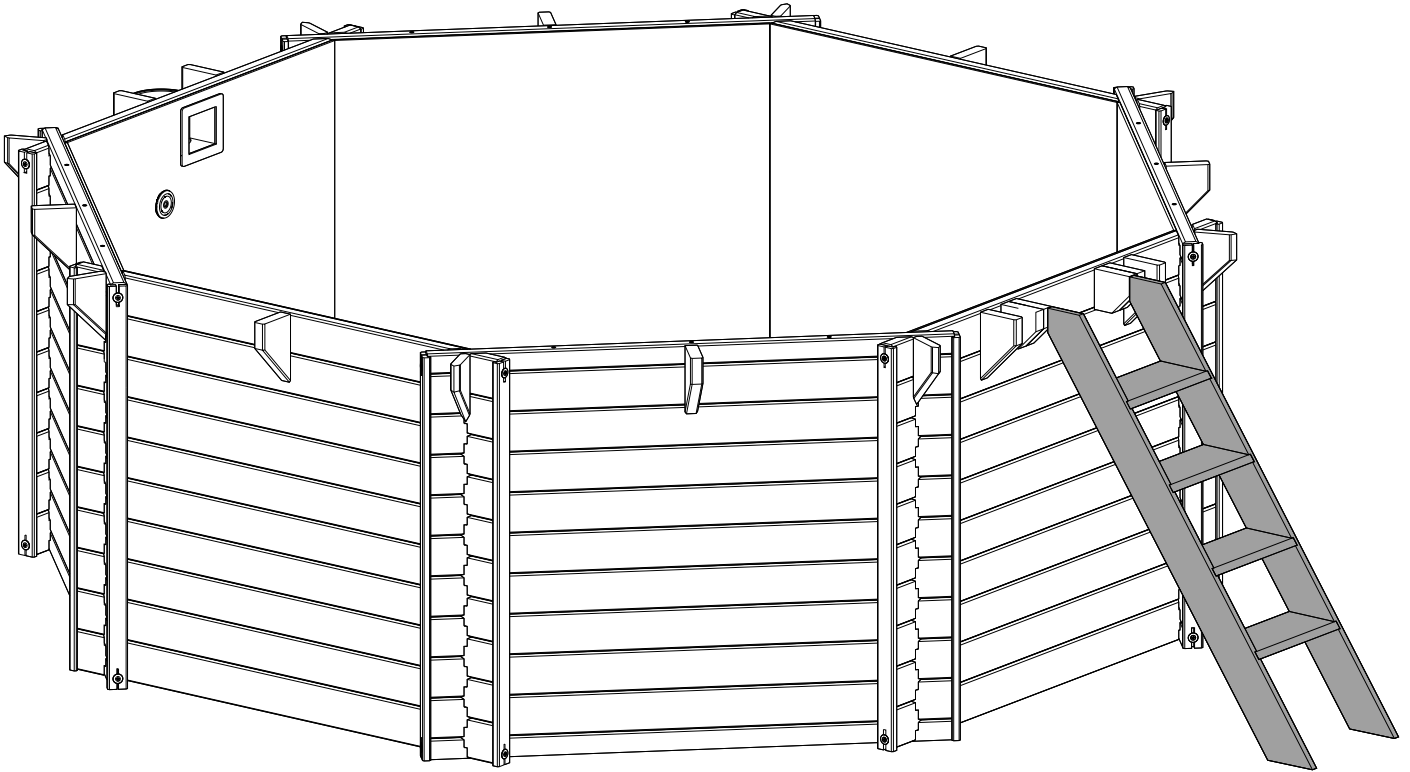

BENÖTIGTE TEILE FÜR DIESEN SCHRITT

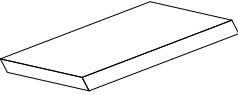

T3 x4
 L: 440 mm
 B: 145 mm
 T: 28 mm

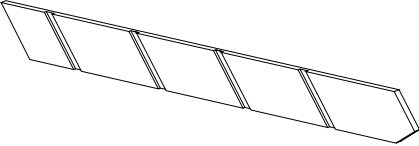

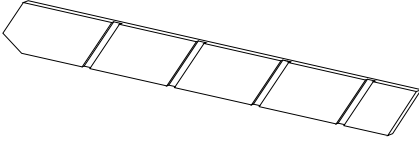

T1 x1
 L: 1621 mm
 B: 145 mm
 T: 28 mm





T2 x1
 L: 1621 mm
 B: 145 mm
 T: 28 mm



S2 3,5 x 25 mm  x12



S3 4,5 x 60 mm  x16



S10 x2

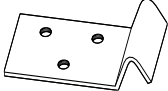

S9 x2

9. MONTAGE DER TREPPE

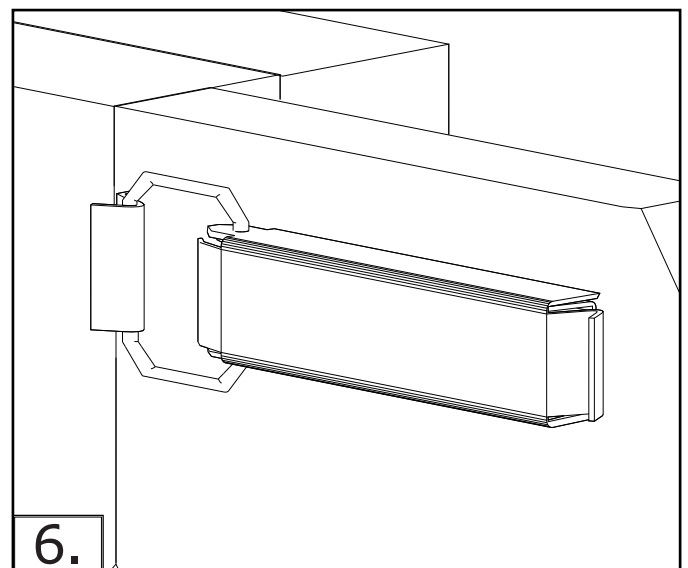
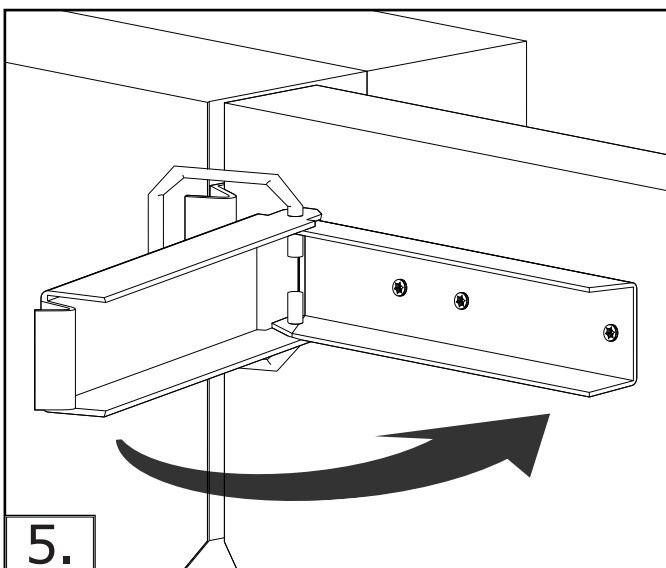
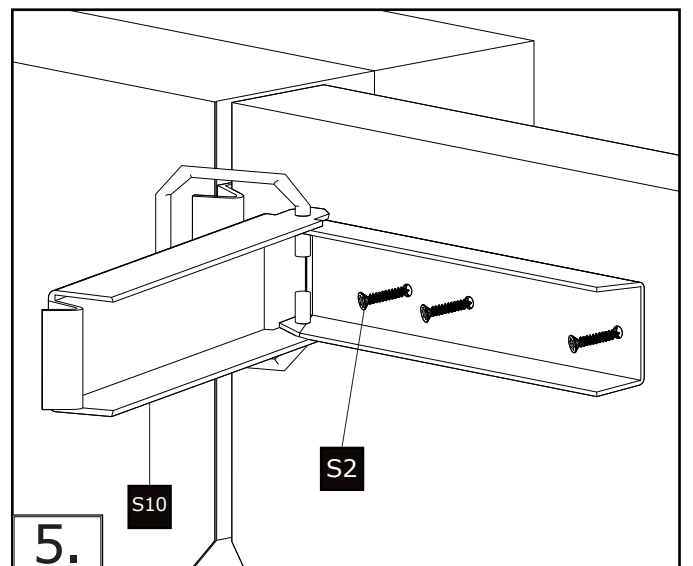
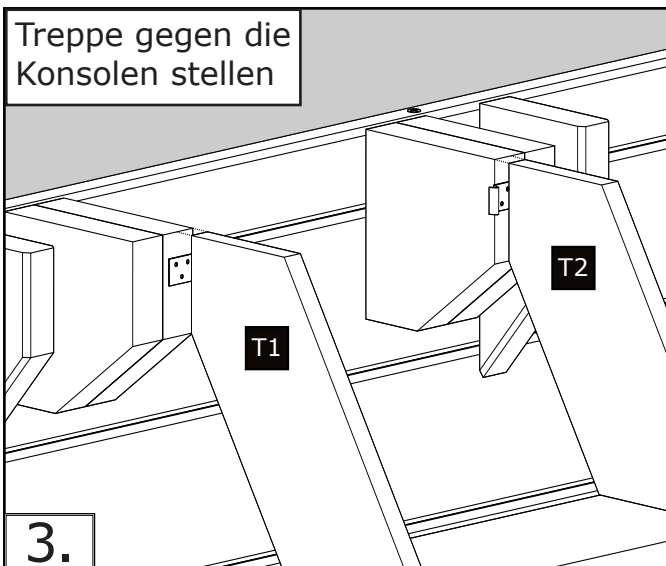
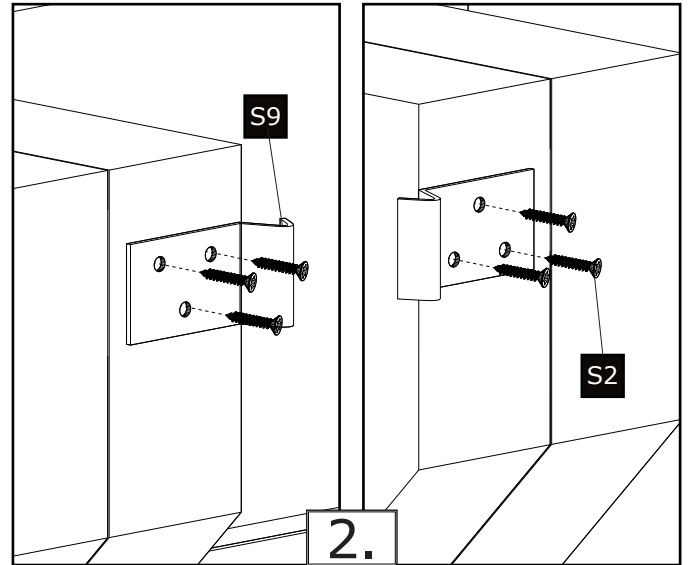
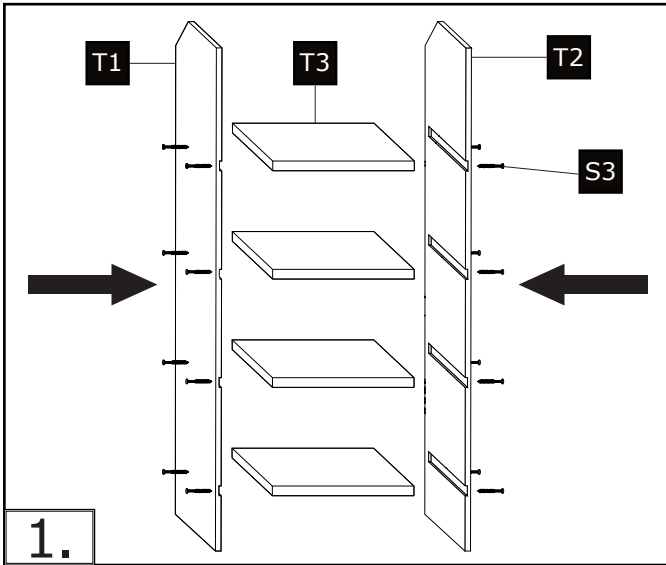

10. MONTAGE DES DECKS - ÜBERSICHT

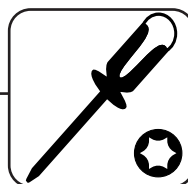
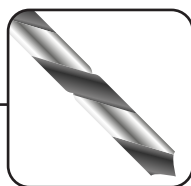
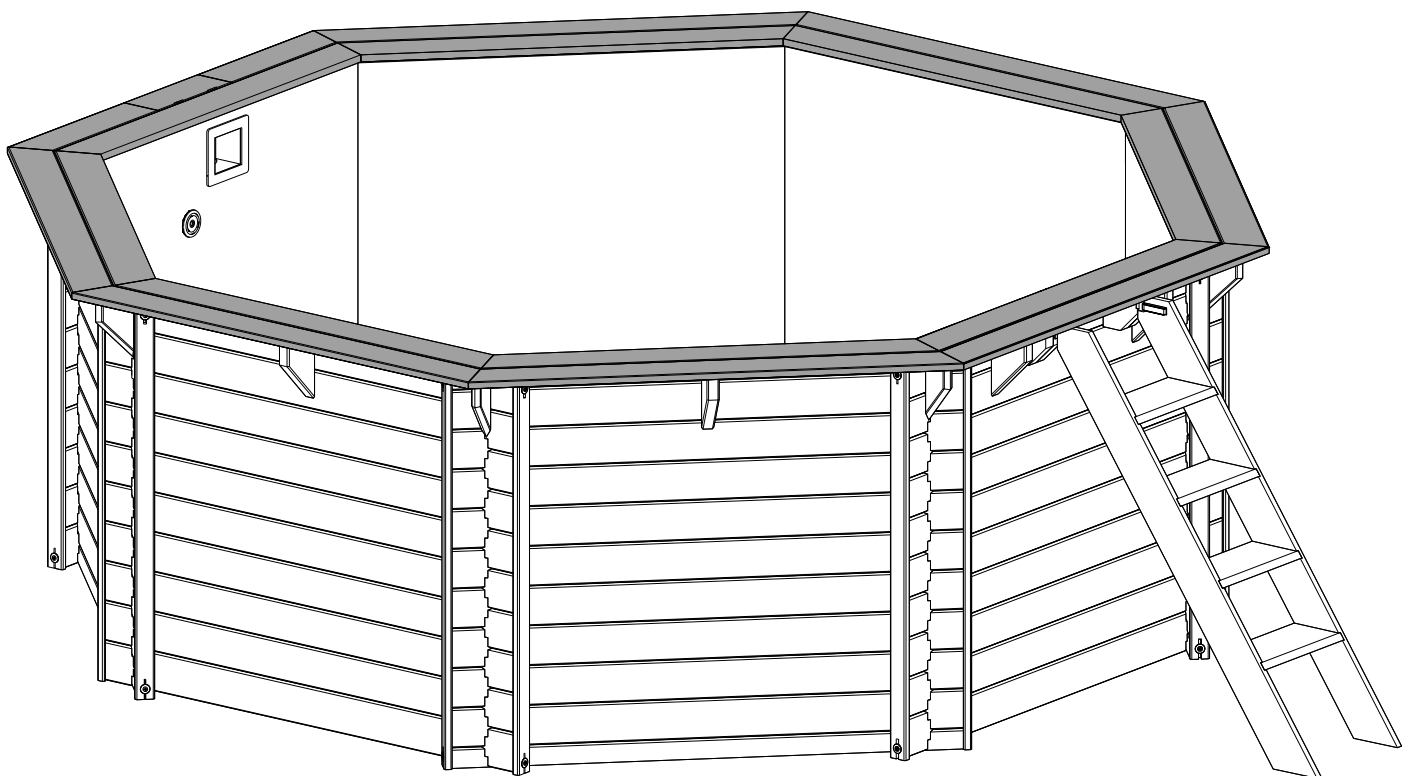

BENÖTIGTE TEILE FÜR DIESEN SCHRITT

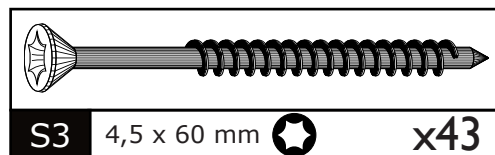
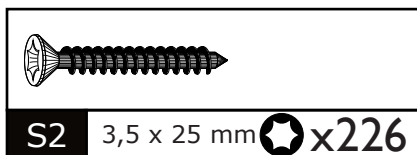
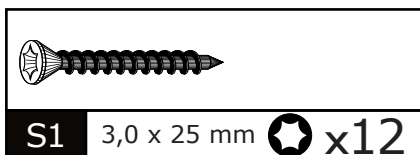
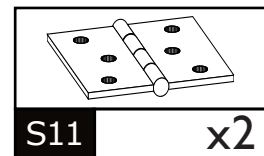
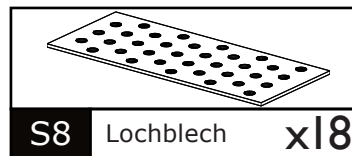
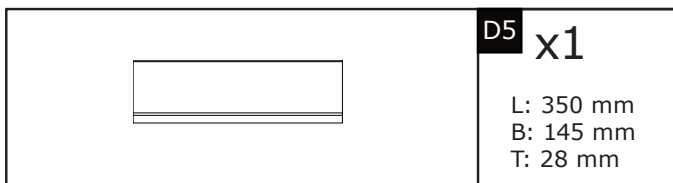
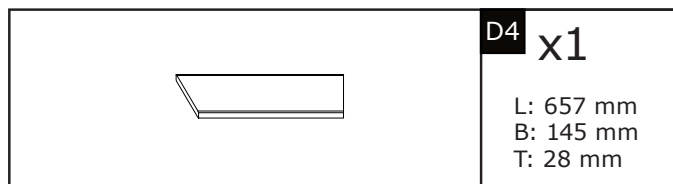
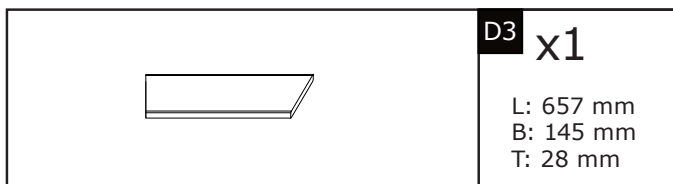
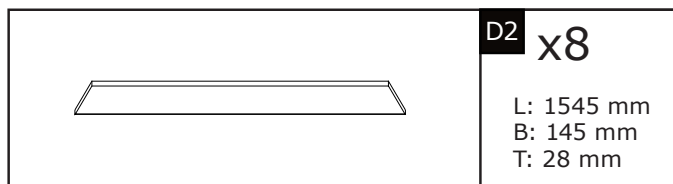
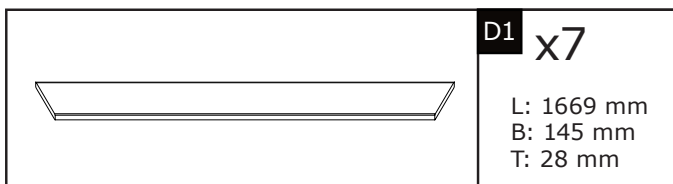

10. MONTAGE DES DECKS

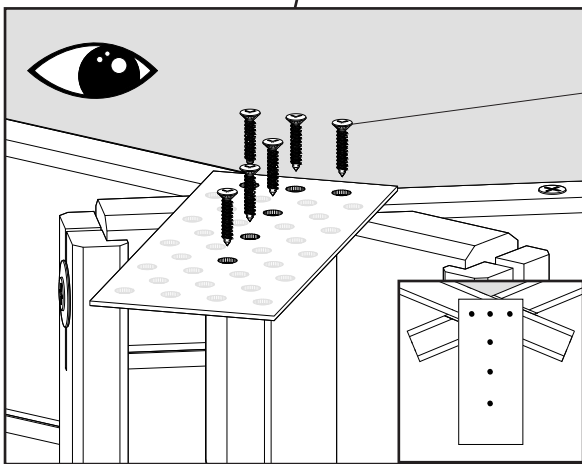
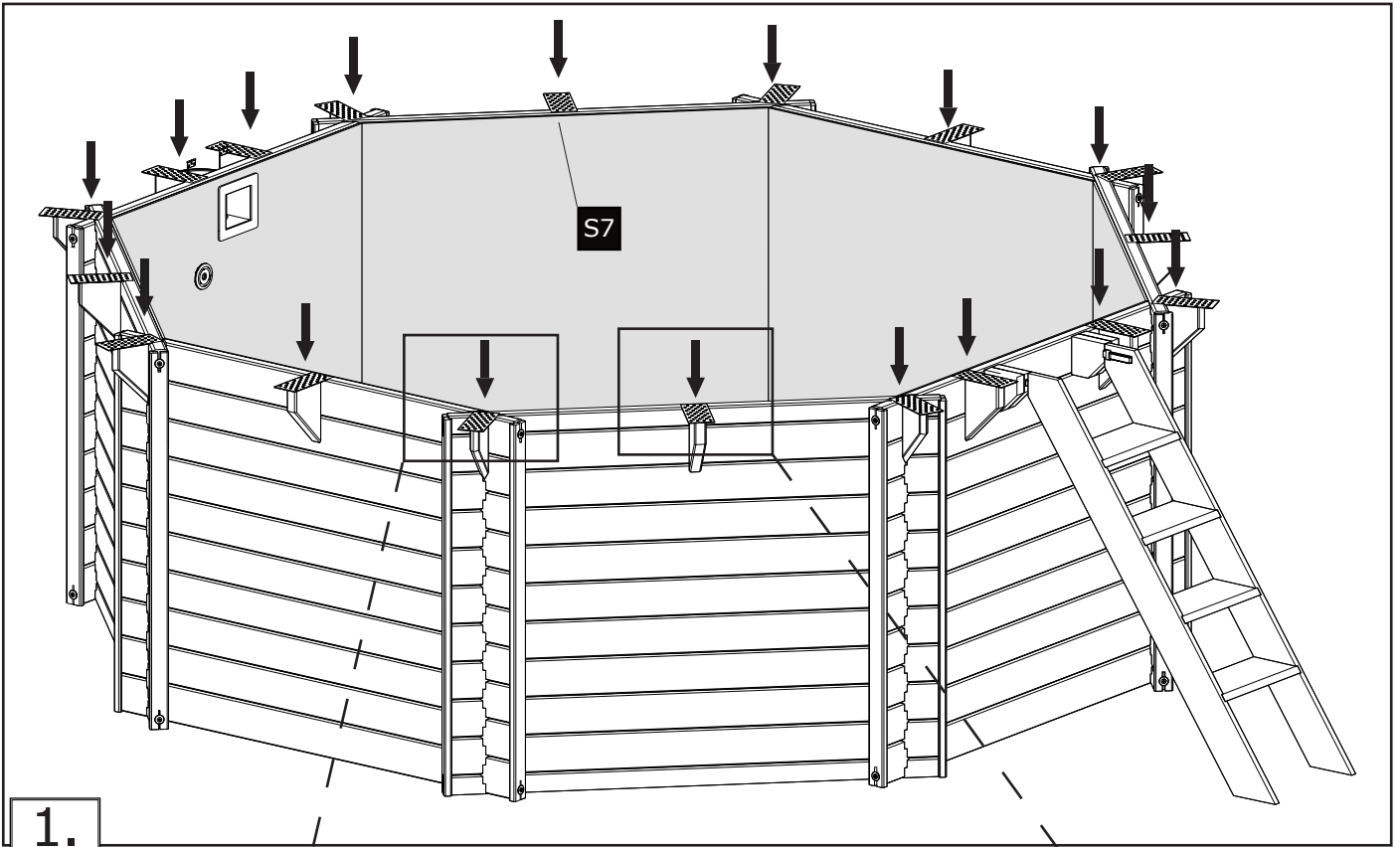

S2
6 Schrauben
pro Blech

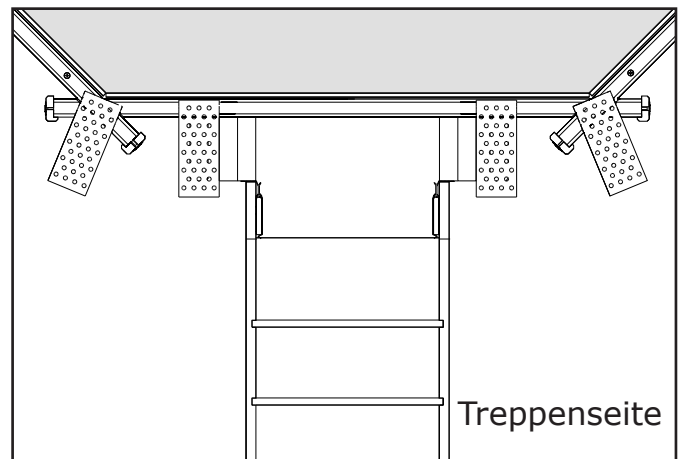
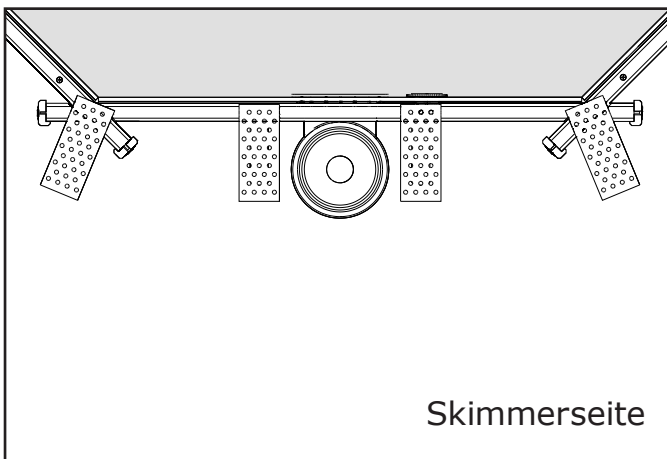
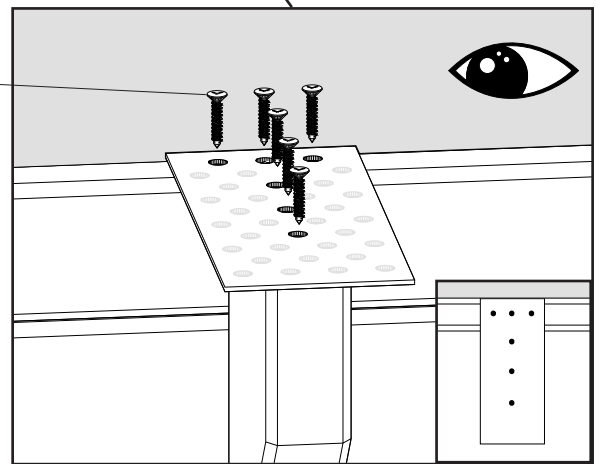

10. MONTAGE DES DECKS

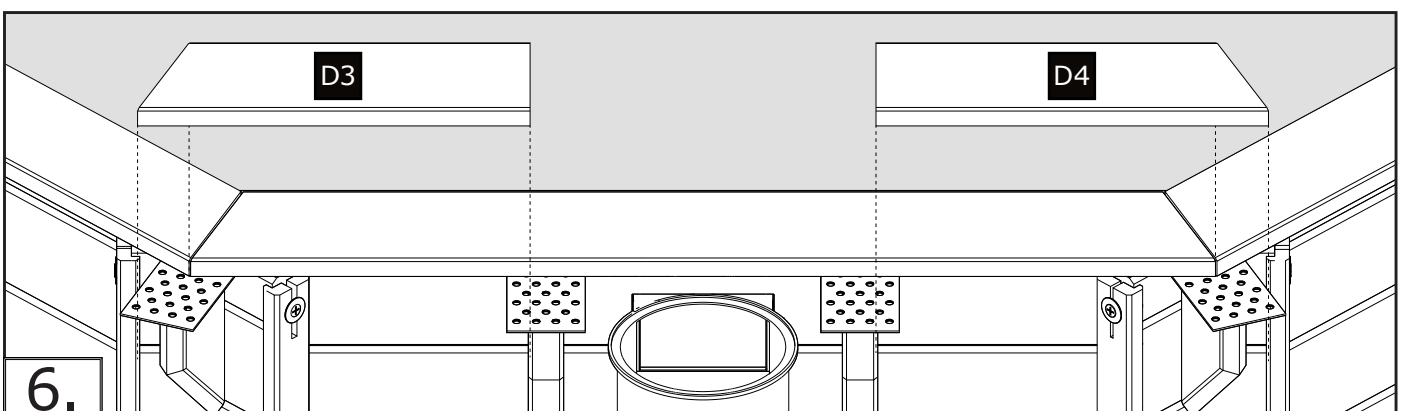
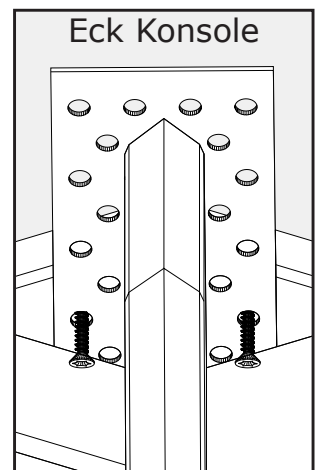
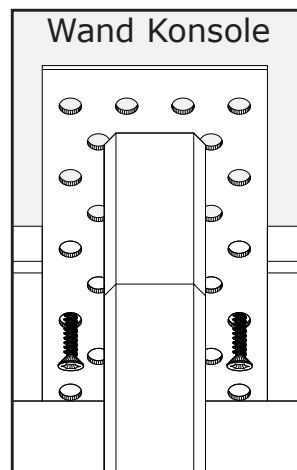
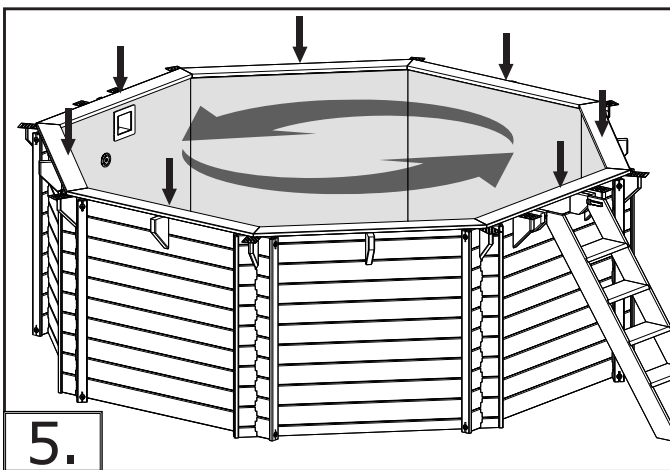
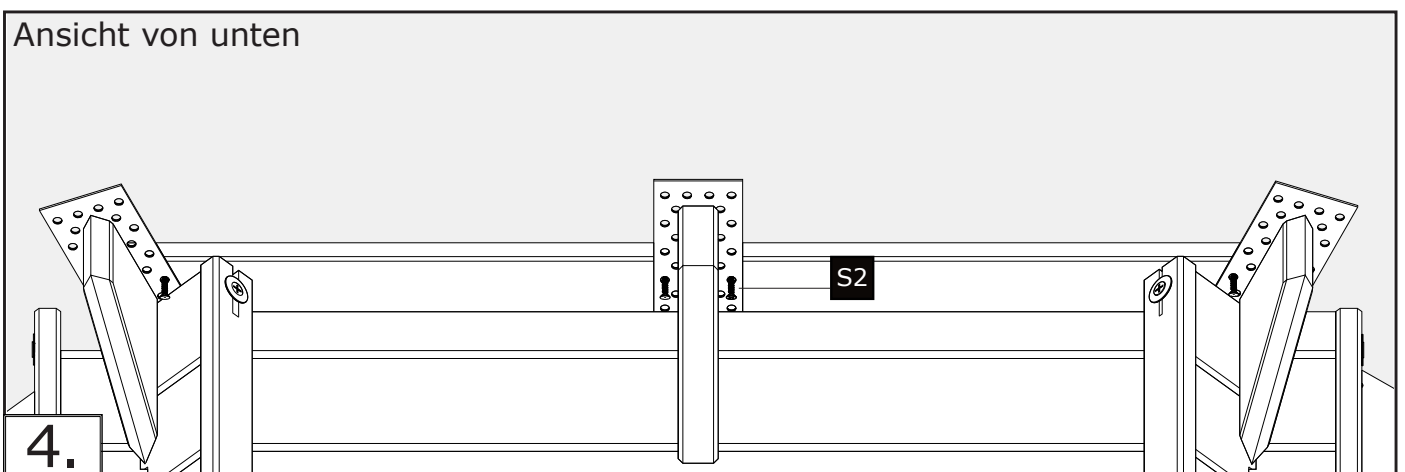
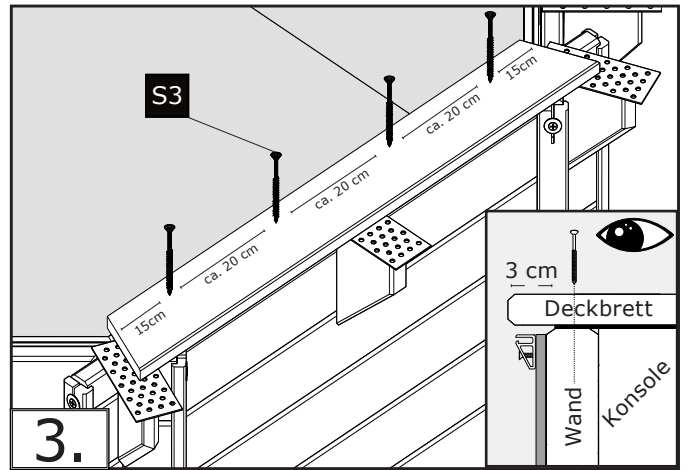
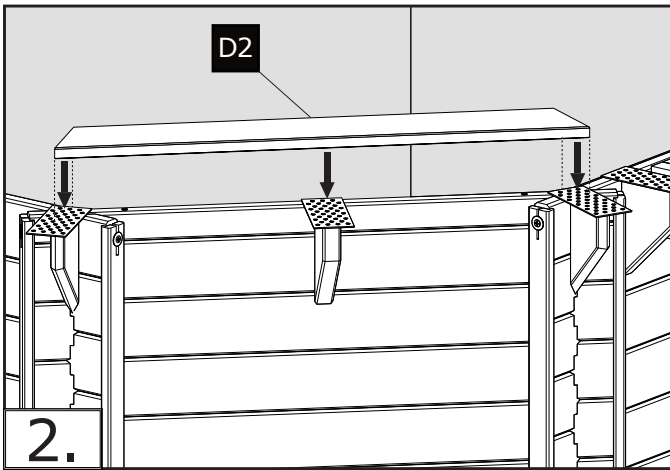

10. MONTAGE DES DECKS

Ansicht von unten

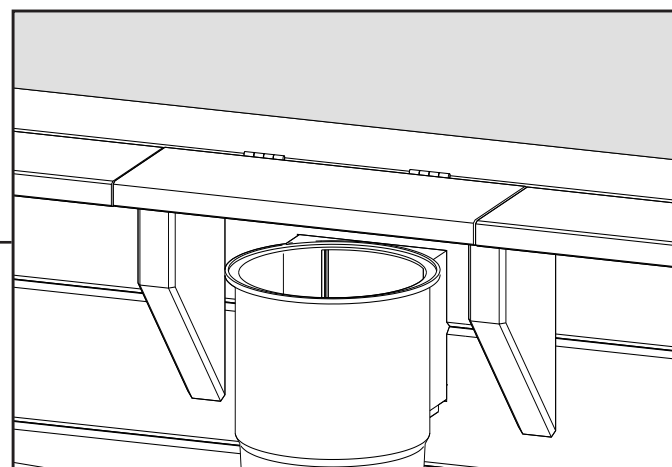
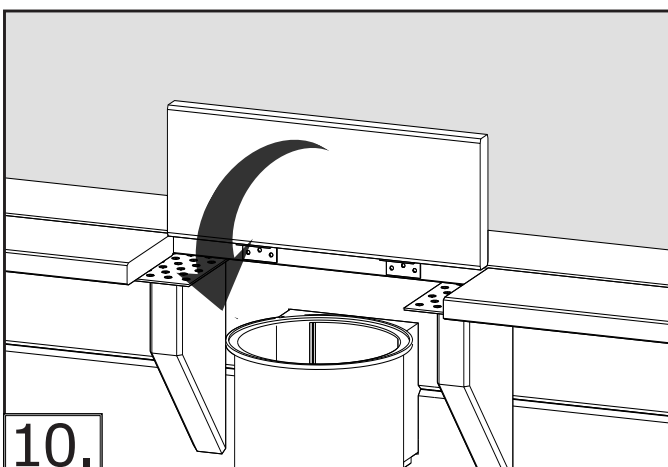
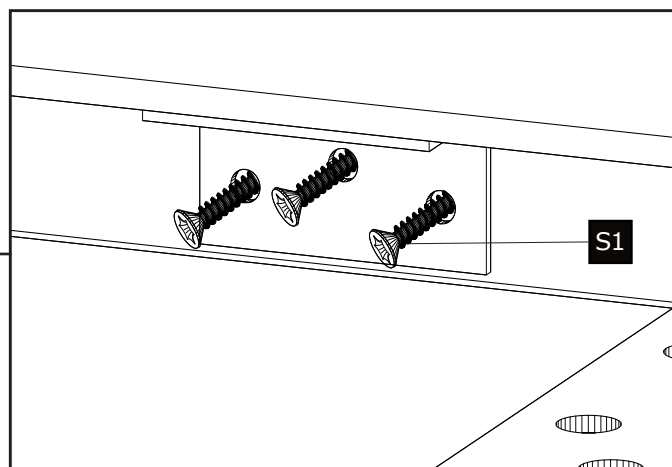
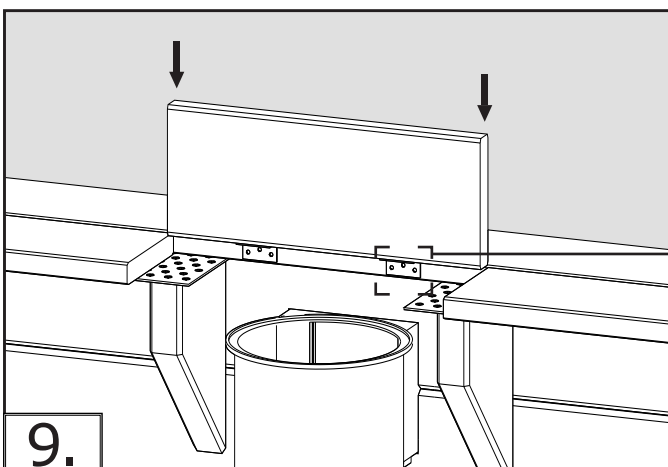
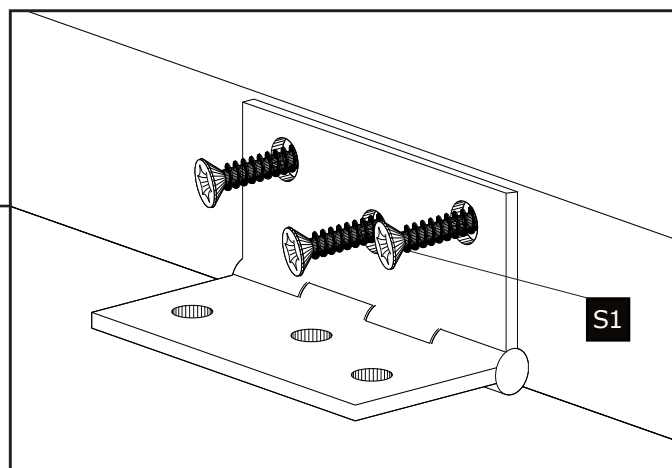
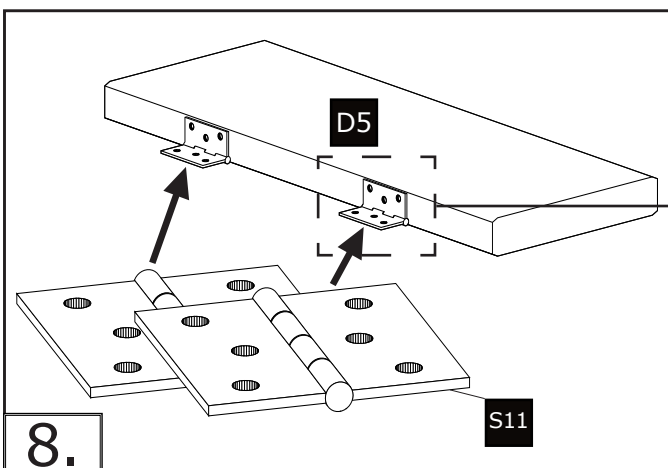
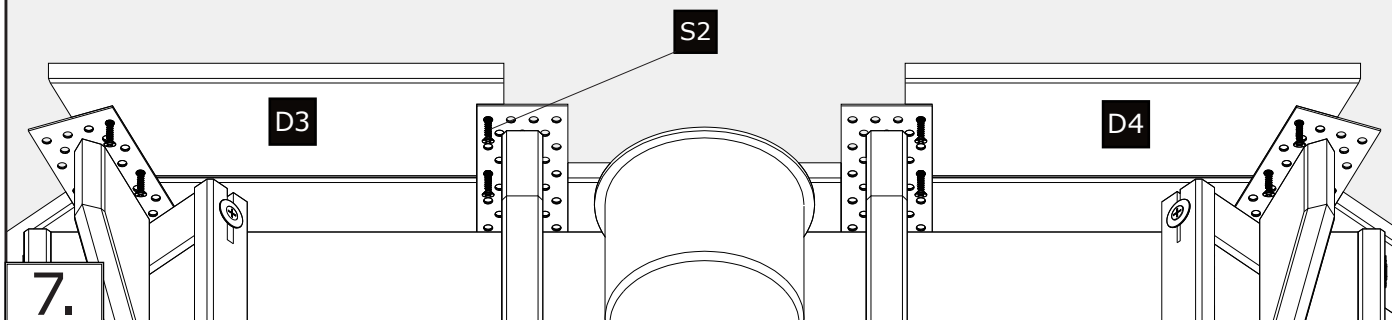

10. MONTAGE DES DECKS

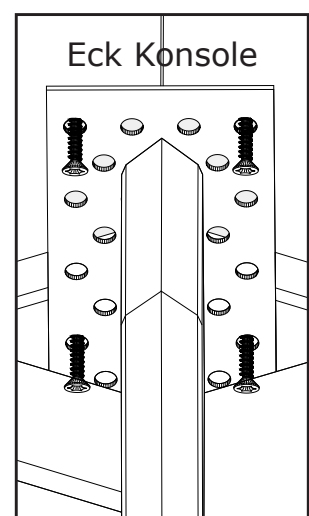
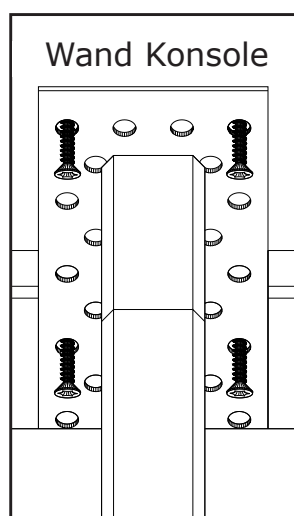
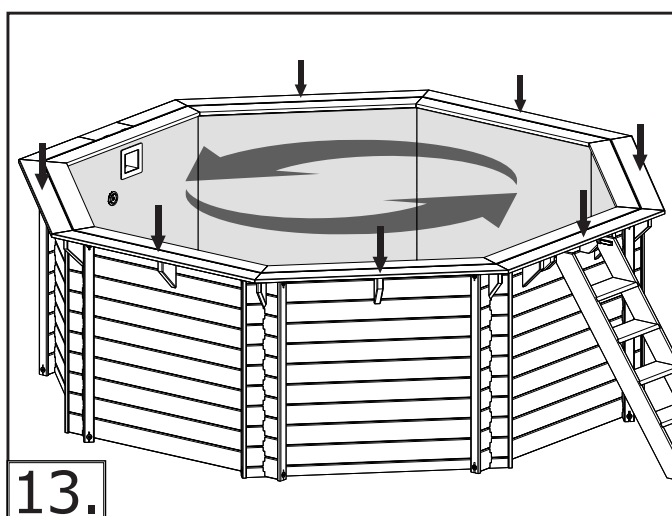
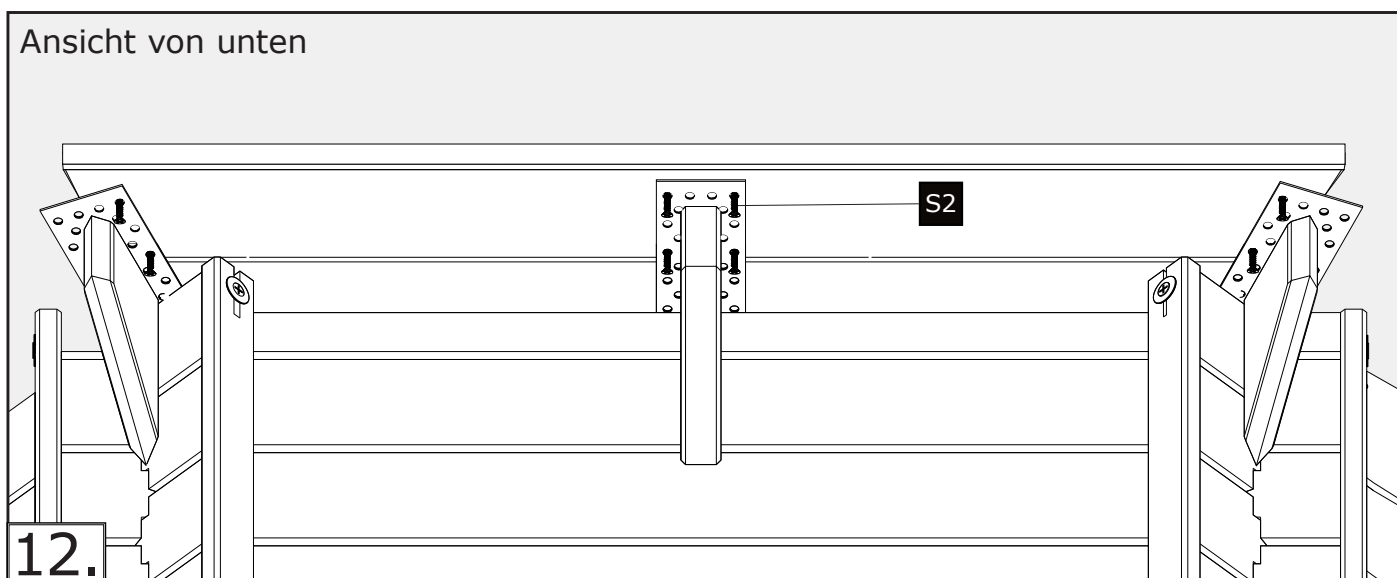
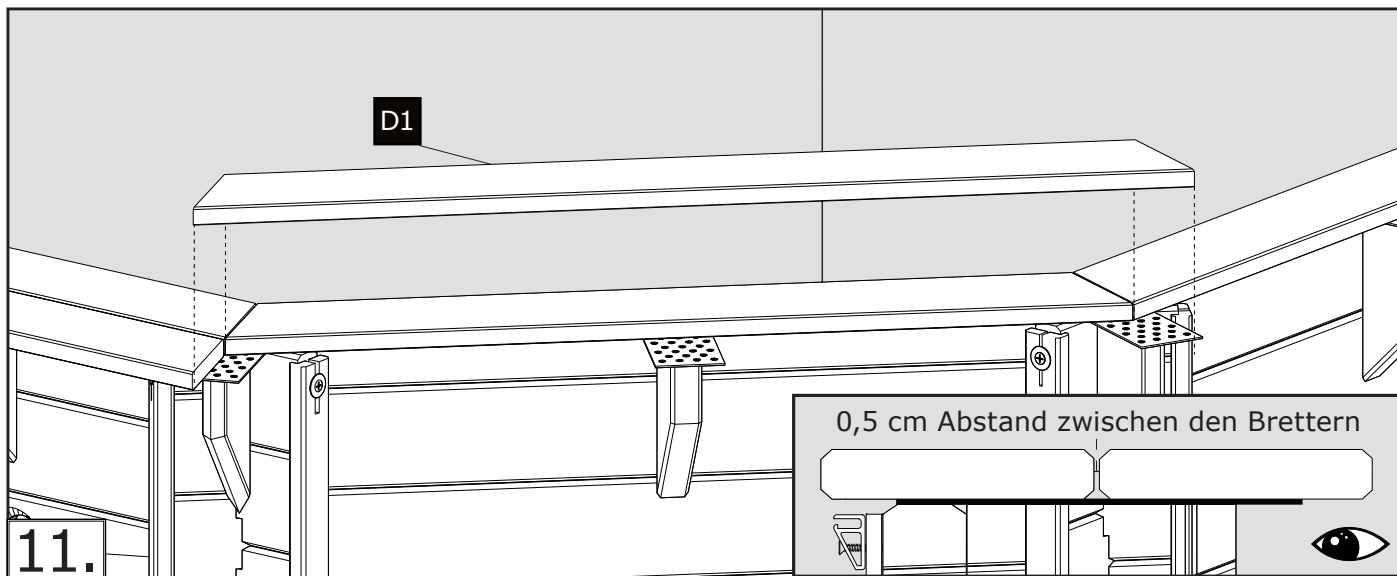

11. [OPTIONAL] MONTAGE DER LEITER - ÜBERSICHT

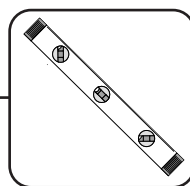
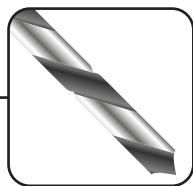
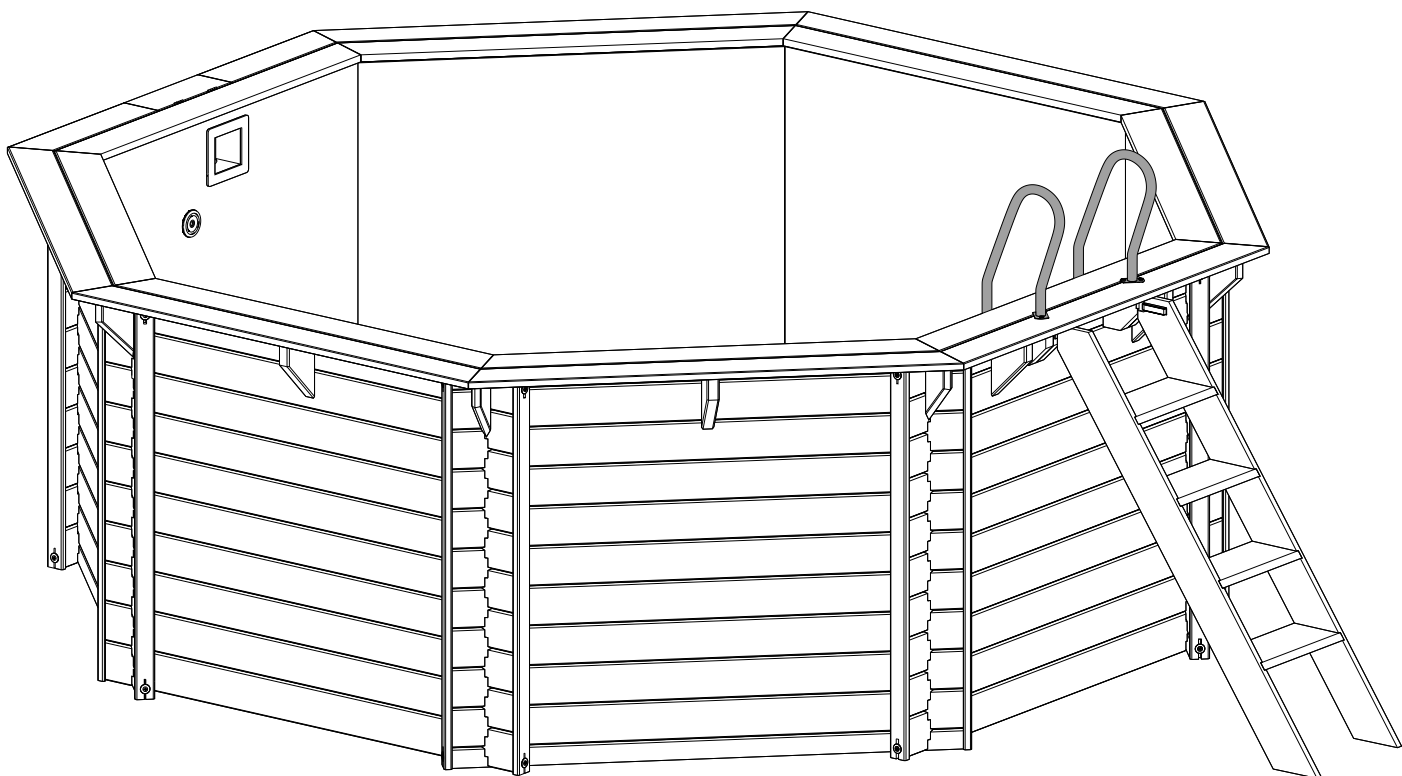

BENÖTIGTE TEILE FÜR DIESEN SCHRITT

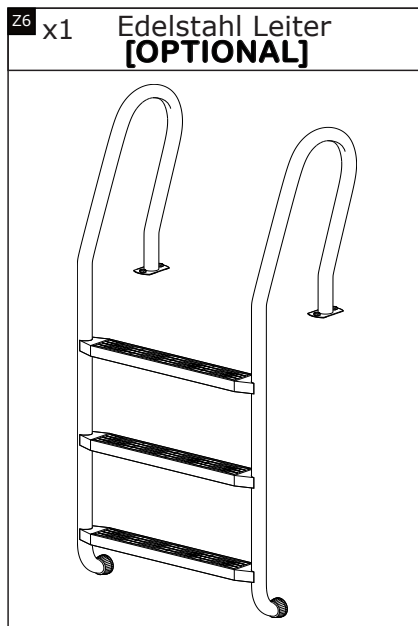

11. [OPTIONAL] MONTAGE DER LEITER

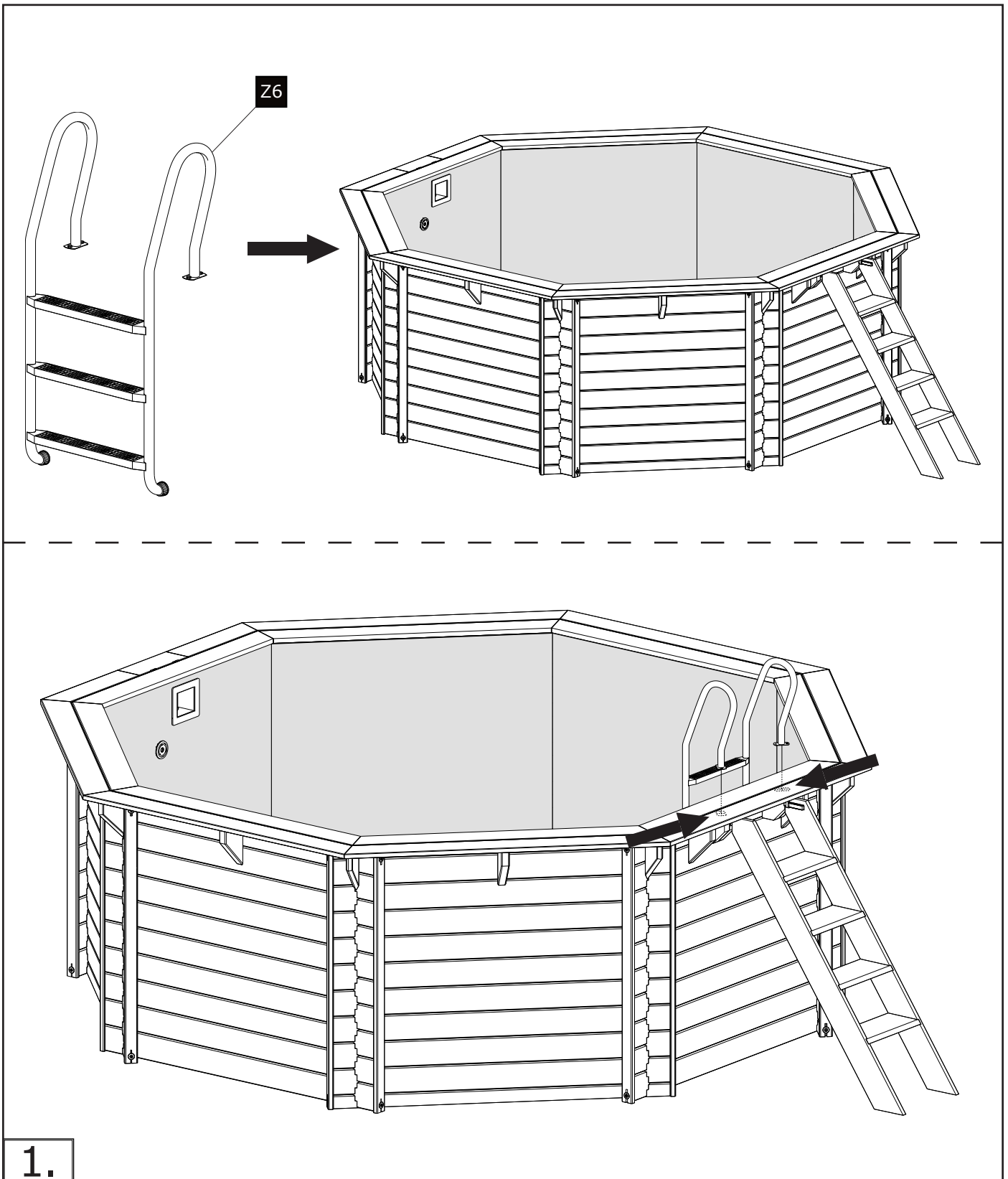

11. [OPTIONAL] MONTAGE DER LEITER

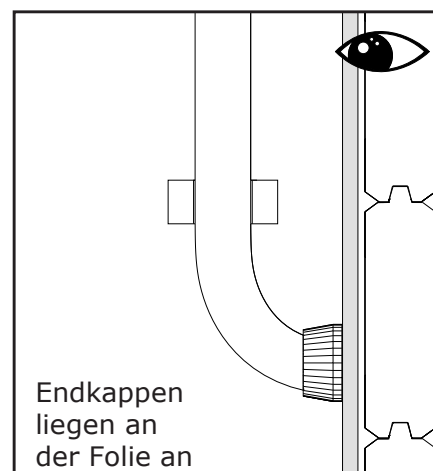
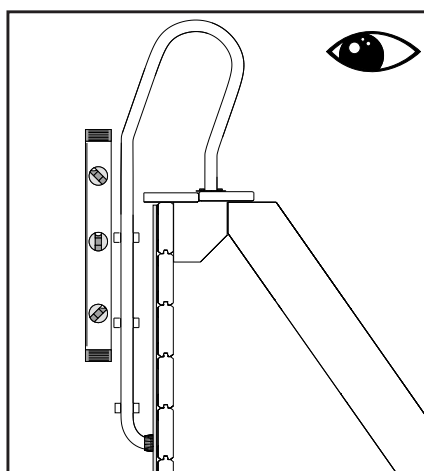
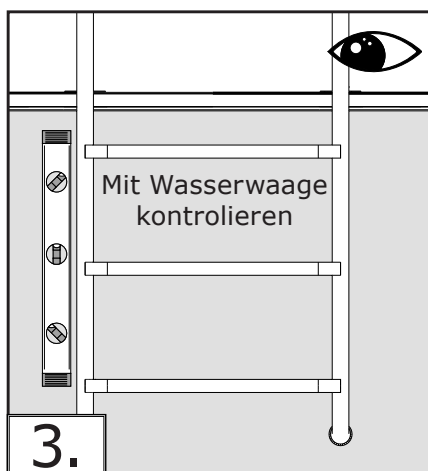

Schraubenlöcher über der Treppen-Konsole ausrichten

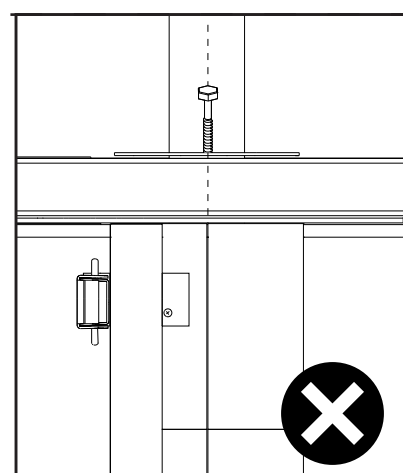
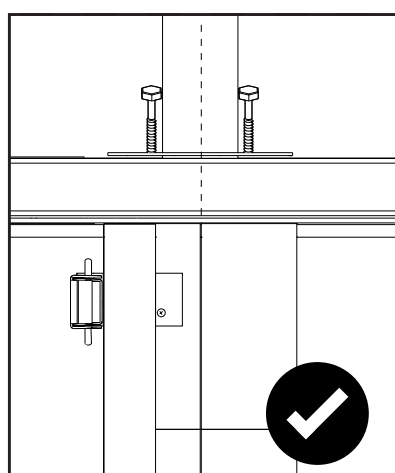
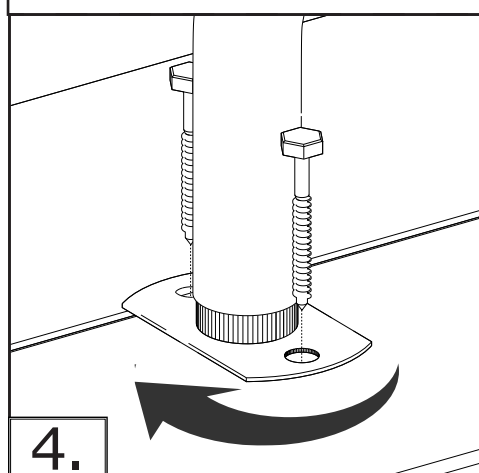

12. [OPTIONAL] MONTAGE DER ECKLEISTE - ÜBERSICHT

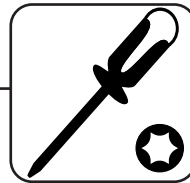
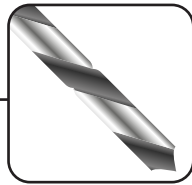
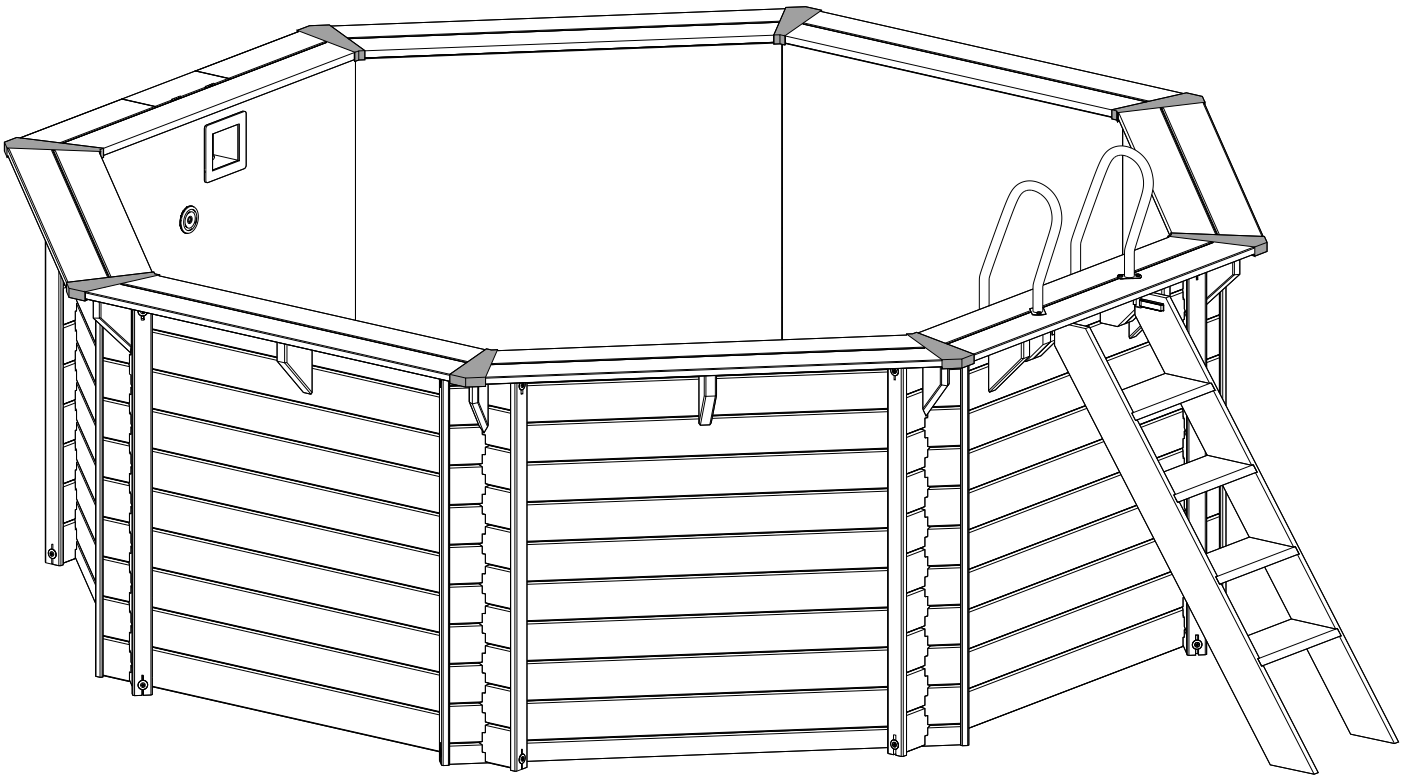

BENÖTIGTE TEILE FÜR DIESEN SCHRITT

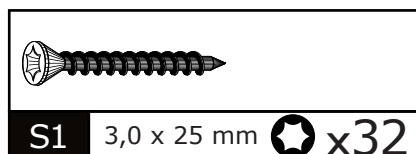
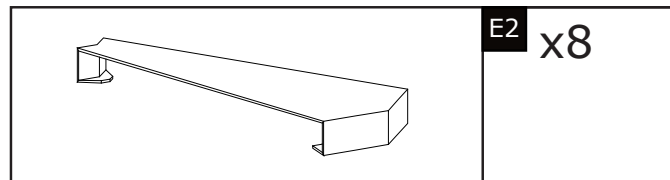

12. [OPTIONAL] MONTAGE DER ECKLEISTE

